

TECHNICAL MANUAL

**OPERATOR'S AND ORGANIZATIONAL
MAINTENANCE MANUAL**

HOW TO USE
THIS MANUAL
PAGE iii

DESCRIPTION
AND DATA
PAGE 1-2

OPERATOR'S
CONTROLS,
INDICATOR
AND CONNECTORS
PAGE 2-1

OPERATOR'S
PREVENTIVE
MAINTENANCE
PAGE 3-1

TROUBLESHOOTING
PAGE 4-9

ORGANIZATIONAL
MAINTENANCE
PROCEDURES
PAGE 4-10

MAINTENANCE
ALLOCATION
CHART
PAGE B-0

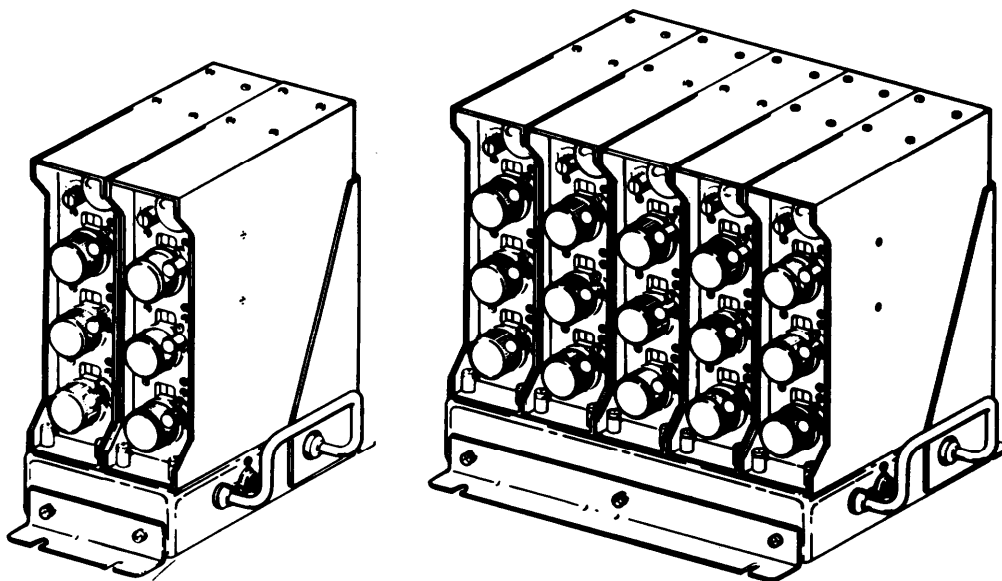

**2-CHANNEL MULTIPLEXER TD-1288()/GRC
(NSN 5820-01-090-1414)**

AND

**5-CHANNEL MULTIPLEXER TD-1289()(V)/GRC
(NSN 5820-01-090-5407)**



SAFETY STEPS TO FOLLOW IF SOMEONE IS THE VICTIM OF ELECTRICAL SHOCK



+ SAFETY STEPS +

- 1** DO NOT TRY TO PULL OR GRAB THE INDIVIDUAL.
- 2** IF POSSIBLE, TURN OFF THE ELECTRICAL POWER.
- 3** IF YOU CANNOT TURN OFF THE ELECTRICAL POWER, PULL, PUSH, OR LIFT THE PERSON TO SAFETY USING A WOODEN POLE OR A ROPE OR SOME OTHER INSULATING MATERIAL.
- 4** SEND FOR HELP AS SOON AS POSSIBLE.
- 5** AFTER THE INJURED PERSON IS FREE OF CONTACT WITH THE SOURCE OF ELECTRICAL SHOCK, MOVE THE PERSON A SHORT DISTANCE AWAY AND IMMEDIATELY START ARTIFICIAL RESUSCITATION. REFER TO FM 21-11 FOR ARTIFICIAL RESPIRATION PROCEDURES.

WARNING

Insure couplers, band-pass filters and termination units in all vacant filter jacks are securely connected. Loose connections can cause rf burns.

Do not touch the antenna while the transceiver is transmitting.

Shut off or disconnect all transceivers before performing maintenance or troubleshooting on any part of the multiplexer.

Insure all transceivers have their power source grounds joined together at the multiplexer ground lug before connecting coaxial cables. Connect an earth ground to the multiplexer ground lug.

Adequate ventilation should be provided while using TRICHLOROTRIFLUOROETHANE. Prolonged breathing of vapor should be avoided. The solvent should not be used near heat or open flame; the products of decomposition are toxic and irritating. Since TRICHLOROTRIFLUOROETHANE dissolves natural oils, prolonged contact with skin should be avoided. When necessary, use gloves which the solvent cannot penetrate. If the solvent is taken internally, consult a physician immediately.

WARNING

Washington, DC, 24 August 1983

OPERATOR'S AND ORGANIZATIONAL MAINTENANCE MANUAL

2-CHANNEL MULTIPLEXER TD-1288()/GRC
(NSN 5820-01-090-1414)
AND
5-CHANNEL MULTIPLEXER TD-1289()/GRC
(NSN 5820-01-090-5407)

REPORTING ERRORS AND RECOMMENDING IMPROVEMENTS

You can help improve this manual. If you find any mistakes or if you know of a way to improve the procedures, please let us know. Mail your letter, DA Form 2028 (Recommended Changes to Publications and Blank Forms), or DA Form 2028-2 located in back of this manual direct to: Commander, US Army Communications-Electronics Command and Fort Monmouth, ATTN: DRSEL-ME-MP Fort Monmouth, New Jersey 07703. A reply will be furnished to you.

		Page
	HOW TO USE THIS MANUAL	ii
CHAPTER 1	INTRODUCTION	
Section I	General Information	1-1
	II Description and Data	1-2
	III Principles of Operation	1-9
CHAPTER 2	OPERATING INSTRUCTIONS	
Section I	Description and Use of Operator's Controls, Indicators, and Connectors	2-1
	II Operation Under Usual Conditions	2-5
	III Operation Under Unusual Conditions	2-16

CHAPTER 3	OPERATOR'S MAINTENANCE INSTRUCTIONS		
Section	I	Introduction	3-1
	II	Lubrication	3-1
	III	Operator's Preventive Maintenance	3-1
	IV	Troubleshooting	3-5
CHAPTER 4	ORGANIZATIONAL MAINTENANCE INSTRUCTIONS		
Section	I	Introduction	4-1
	II	Repair Parts, Tools, and Test Equipment	4-1
	III	Service Upon Receipt	4-2
	IV	Installation Instructions	4-3
	V	Organizational Preventive Maintenance	4-7
	VI	Troubleshooting	4-9
	VII	Maintenance Procedures	4-10
APPENDIX A.	REFERENCES		
	B. MAINTENANCE ALLOCATION		
Section	I	Introduction	B-0
	II	Maintenance Allocation Chart for Multiplexer TD-1288()/GRC. .	B-3
	III	Maintenance Allocation Chart for Multiplexer TD-1289() (V)/GRC	B-4
	IV	Tool and Test Equipment Requirements for Multiplexer TD-1288 ()/GRC and TD-1289()(V)/GRC	B-5
	V	Remarks	B-8
APPENDIX C.	COMPONENTS OF END ITEM AND BASIC ISSUE ITEMS LIST		
Section	I	Introduction	C-1
	II	Integral Components of End Item for TD-1288()/GRC	C-2
	III	integral Components of End Item for TD-1289()(V)/GRC	C-3
APPENDIX D.	ADDITIONAL AUTHORIZATION LIST (Not applicable)		
	E. EXPENDABLE SUPPLIES AND MATERIALS LIST		
Section	I	Introduction	E-1
	II	Expendable Supplies and Materials	E-2

HOW TO USE THIS MANUAL

The front cover index will assist you in quickly locating information. It identifies information frequently used by the operator. Each item appearing on the front cover is boxed and identified by topic with the page number in the manual where the information is located. The page in the manual used in conjunction with the front cover has a black box on the edge of the page. Bend the manual in half and follow the margin index to the page with the black edge marker.

Entries within the table of contents which duplicate the entries on the front cover index are highlighted with a box.

**NO ONE EVER REPAIRED OR TESTED
ELECTRONIC EQUIPMENT WITHOUT FIRST
READING THE OPERATION AND
MAINTENANCE MANUAL.**

**IT IS THE MOST
IMPORTANT TOOL
YOU HAVE !!!**

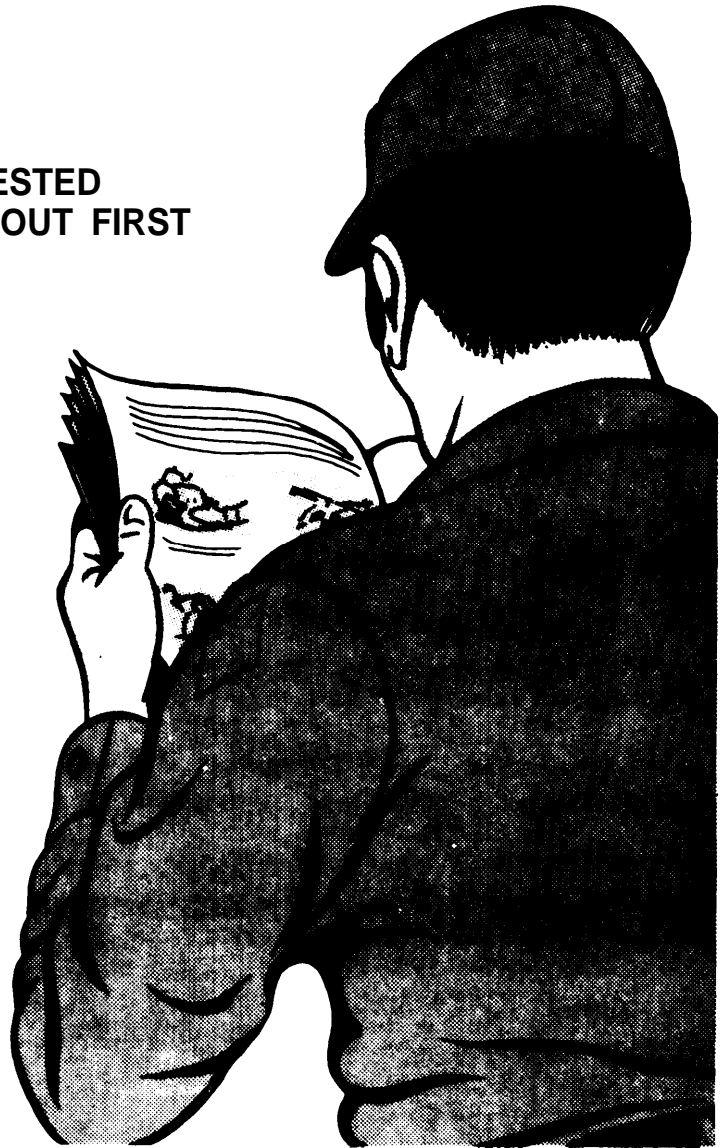

CHAPTER 1

INTRODUCTION

SECTION I

GENERAL INFORMATION

1.1 SCOPE.

This manual provides operator's and organizational maintenance instructions for the 2-Channel Multiplexer TD-1288 ()/GRC and the 5-Channel Multiplexer TD-1289 ()(V)/GRC. The 2-channel and the 5-channel multiplexer are primarily used with the RT-524/VRC and the RT-246/VRC which are components of the AN/VRC-12 radio family.

1.2 CONSOLIDATED INDEX OF ARMY PUBLICATIONS AND BLANK FORMS.

Refer to the latest issue of DA Pam 310-1 to determine whether there are new editions, changes or additional publications pertaining to the equipment.

1.3 MAINTENANCE FORMS, RECORDS, AND REPORTS.

a. Reports of Maintenance and Unsatisfactory Equipment. Department of the Army forms and procedures used for equipment maintenance will be those described by TM 38-750, The Army Maintenance Management System.

b. Report of Packaging and Handling Deficiencies. Fill out and forward SF 364 (Report of Discrepancy (ROD)) as prescribed in AR 735-11-2/DLAR 4140.55/ NAVMATINST 4355.73/AFR 400-54/MCO 4430.3E.

c. Discrepancy in Shipment Report (DISREP) (SF 361). Fill out and forward Discrepancy in Shipment Report (DISREP) (SF 361) as prescribed in AR 55-38/ NAVSUPINST 4610.33 B/AFR 75-18/MCO P4610.19C/DLAR 4500.15.

1.4 ADMINISTRATIVE STORAGE.

Administrative storage of equipment issued to and used by Army activities shall be in accordance with TM 740-90-1.

1.5 DESTRUCTION OF ARMY ELECTRONICS MATERIEL.

Destruction of Army electronics materiel to prevent enemy use shall be in accordance with TM 750-244-2.

1-6 HAND RECEIPT (-HR) MANUALS.

This manual has a companion document with a TM number followed by “-HR” (which stands for Hand Receipt). The TM 11-5820-880-12-HR consists of preprinted hand receipts (DA Form 2062) that list end item related equipment (i.e, COEI, BII, and AAL) you must account for. As an aid to property accountability, additional -HR manuals may be requisitioned from The US Army Adjutant General Publications Center, Baltimore, MD, in accordance with procedures in Chapter 3, AR 310-2, and DA Pam 310-10-2.

1-7 REPORTING EQUIPMENT IMPROVEMENT RECOMMENDATIONS (EIR).

If your multiplexer needs improvement, let us know. Send us an EIR. You, the user, are the only one who can tell us what you don't like about your equipment. Let us know why you don't like the design. Put it on an SF 368 (Quality Deficiency Report). Mail it to Commander, US Army Communications-Electronics Command and Fort Monmouth, ATTN: DRSEL-ME-MP, Fort Monmouth, NJ 07703. We'll send you a reply.

SECTION II DESCRIPTION AND DATA

1-8 PURPOSE AND USE.

The purpose of the 2-Channel Multiplexer TD-1288 ()/GRC is to allow an operator to use two transceivers with a maximum nominal power output of 60 watts each in the 30.00 MHz to 88.00 MHz frequency range and couple them to a single broadband antenna. The purpose of the 5-Channel Multiplexer TD-1289 () (V)/GRC is to allow an operator to use three to five transceivers with a maximum nominal power output of 60 watts each in the 30.00 MHz to 88.00 MHz frequency range and couple them to a single broadband antenna. The Band-pass Filter F-1482 ()/GRC provides the rf signal isolation and the Coupler CU-2266 ()/GRC or the Coupler CU-2267 ()/GRC provides the rf signal coupling which permits use of a single wideband antenna. Antennas such as AS-1729/VRC, AS-2731/GRC and RC-292 are NOT broadband antennas and must NOT be used with the TD-1288 ()/GRC or the TD-1289 () (V)/GRC. The mast mounted antenna AS-3166 (part of Antenna Group OE-254/GRC) is an example of a broadband antenna suitable for use with the TD-1288 ()/GRC and TO-1289 () (V)/GRC.

1-9 CHARACTERISTICS, CAPABILITIES, AND FEATURES.

- Tuning 30.00 MHz to 88.00 MHz.
- Tuning Lock To prevent detuning during operation.
- Impedance 50-ohms for match with antenna and transceiver.
- Isolation 5% difference between filter frequencies.
- Rf Power Handling Each transceiver to be used must not produce more than a nominal 60 watts output.
- Ground Lug A ground lug on the rear of the couplers provides a connecting point for earth ground.
- Rf Power Monitoring Forward power, reflected power, and phasing at 60W or 6W scale.
- Weight
 - TD-1288 ()/GRC -6.62 Kg (14.6 lb)
 - TD-1289 () (V)3/GRC -10.84 Kg (23.9 lb)
 - TD-1289 () (V)2/GRC -13.11 Kg (28.9 lb)
 - TD-1289 () (V)1/GRC -15.38 Kg (33.9 lb)

1-10 EQUIPMENT DATA.

- Frequency range 30.00 MHz to 88.00 MHz.
- Rf power handling Nominally 60 watts continuous input per channel.
- Temperature range
 - Operating -500 F to + 125° F plus solar radiation at a rate of 360 Btu/ft²/h.
 - Storage -70° F to + 160° F.
- Operating altitude 15,000 feet.
- Operating humidity 95% relative humidity.
- Band-pass Filter input impedance 50 ohms.
- Coupler Antenna output impedance 50 ohms.
- Antenna requirements Nominal 50 ohms broadband antenna with a maximum 3:1 VSWR.

1-11 LOCATION AND DESCRIPTION OF MAJOR COMPONENTS.

- A** 2-Channel Multiplexer, TD-1288 ()/GRC: The 2-channel multiplexer contains two band-pass filters and a coupler. The 2-channel multiplexer allows the simultaneous operation of two transceivers on a single broadband antenna by providing isolation between the two channels.
- B** 3-Channel Multiplexer TD-1289 ()/GRC: The 3-channel multiplexer contains three band-pass filters, two termination units and a coupler. The 3-channel multiplexer allows the simultaneous operation of three transceivers on a single broadband antenna by providing isolation between the three channels.

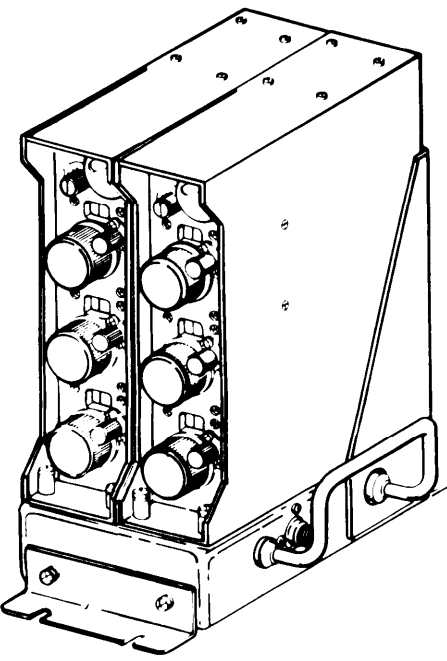

**2-CHANNEL MULTIPLEXER
TD - 1288()/GRC**

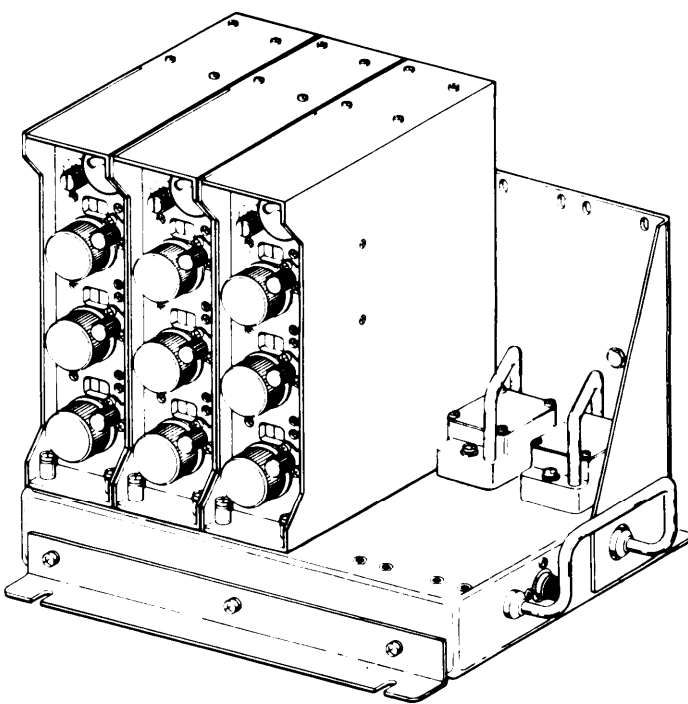

**3-CHANNEL MULTIPLEXER
TD-1289() (V) 3/GRC**

- C** 4-Channel Multiplexer TD-1289 () (V)2/GRC: The 4-channel multiplexer contains four band-pass filters, one termination unit and a coupler. The 4-channel multiplexer allows the simultaneous operation of four transceivers on a single broadband antenna by providing isolation between the four channels.

- D** 5-Channel Multiplexer TD-1289 () (V)1/GRC: The 5-channel multiplexer contains five band-pass filters and a coupler. The 5-channel multiplexer allows the simultaneous operation of five transceivers on a single broadband antenna by providing isolation between the five channels.

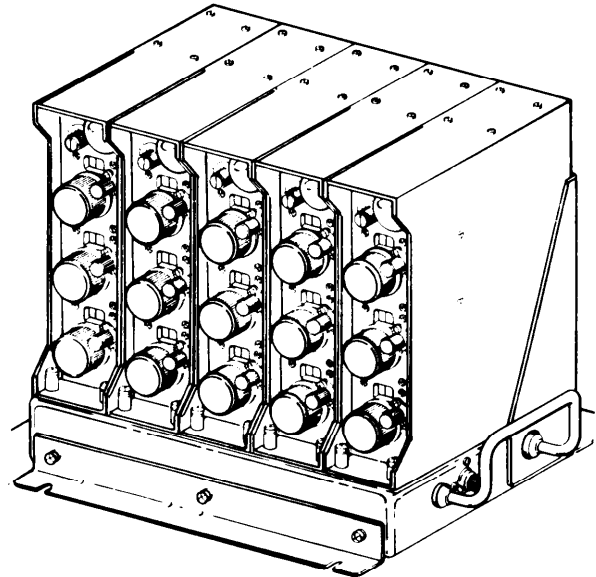
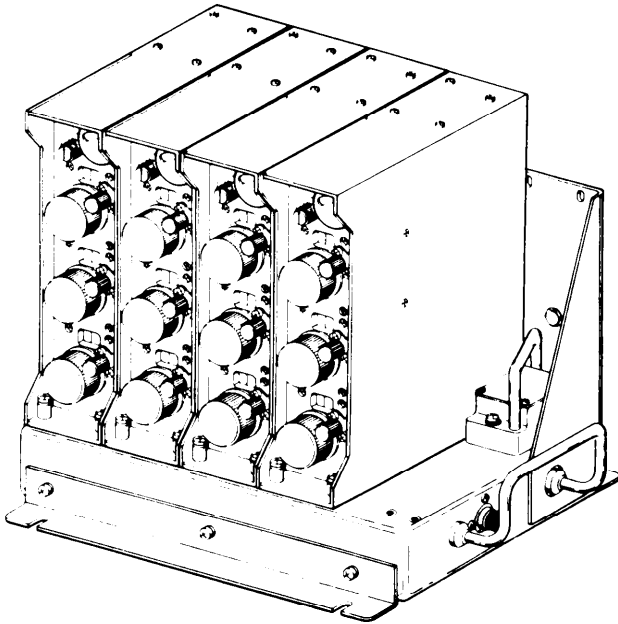

C 4-CHANNEL MULTIPLEXER
TD-1289() (V) 2/GRC

D 5-CHANNEL MULTIPLEXER
TD-1289() (V) 1/GRC

- E** Termination Unit MX-10080 ()/GRC: The termination unit is used in place of a band-pass filter when a channel is to be unused. It simplifies multiplexer operation because it eliminates the need to tune an unused band-pass filter so that the unused filter conforms to required frequency separation.

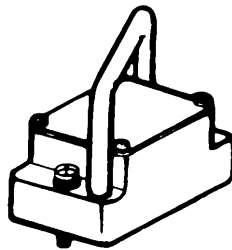

E TERMINATION UNIT
MX - 10080()/GRC

- F** Band-pass Filter F-1482 ()/GRC: The band-pass filter is a manually tuned VHF filter for the frequency range of 30.00 MHz to 88.00 MHz. The band-pass filter has three tuning knobs and three frequency dials. Each tuning knob contains a knob lock. Tuning is accomplished by setting the three knobs to the desired frequency (indicated by the frequency dials), applying rf power from the transceiver and tuning filter for minimum reflected power and zero phasing error. The meter is located on the upper front panel and is used to indicate forward power, reflected power, and phase error. A six position meter function switch to the left of the tuning meter allows selections of these functions for 6-watt or 60-watt full scale meter readings.

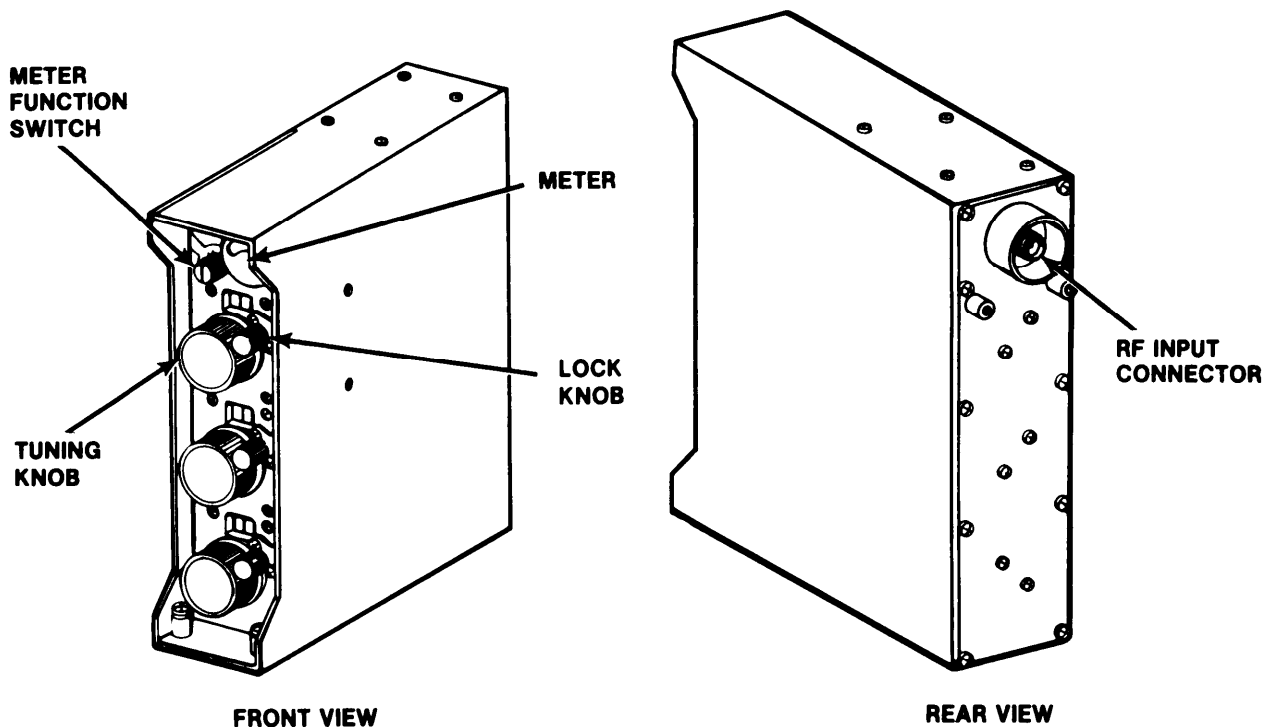

F BANDPASS FILTER F - 1482()/GRC

- G** Coupler CU-2266 ()/GRC: Coupler CU-2266 ()/GRC for the 2-channel multiplexer provides impedance matching between the two band-pass filters mounted on it and the antenna. A ground lug on the rear of the coupler provides a connecting point for earth ground.

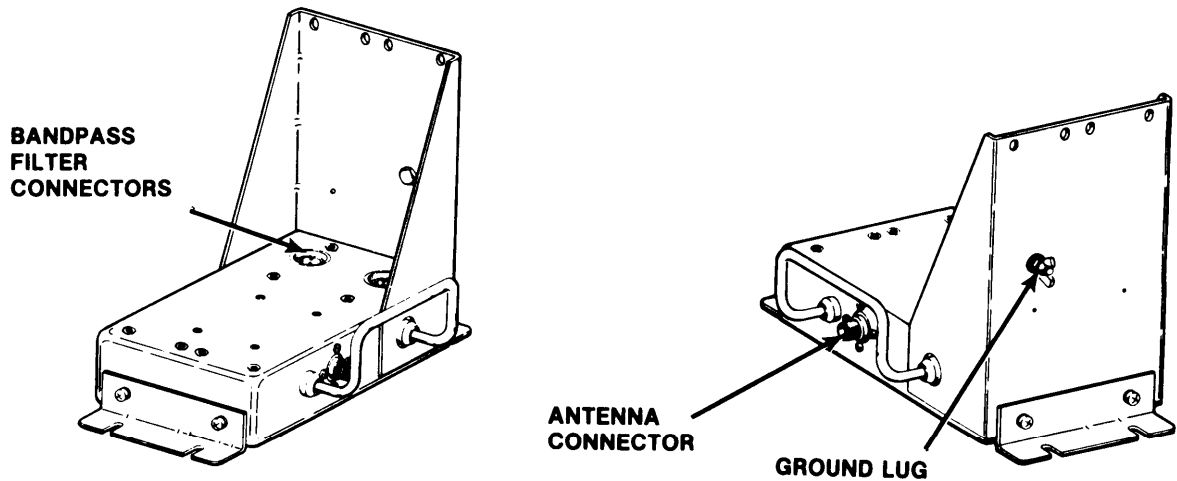

G COUPLER, CU - 2286()/GRC

- Coupler CU-2267 ()/GRC: Coupler CU-2267 ()/GRC for the 5-channel multiplexer provides impedance matching between the band-pass filters or termination units mounted on it and the antenna. A ground lug on the rear of the coupler provides a connecting point for earth ground.

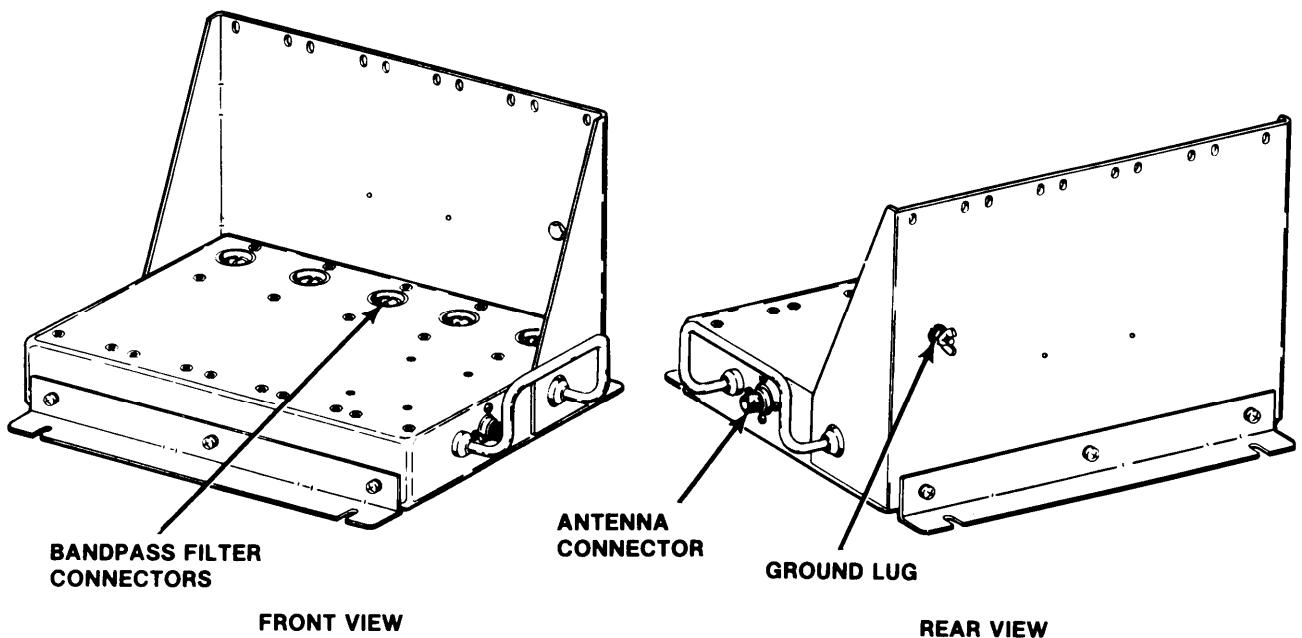

H COUPLER, CU - 2287()/GRC

Multiplexer Case CY-7775 ()/GRC: The Multiplexer Case CY-7775()/GRC provides housing for the 2-channel multiplexer.

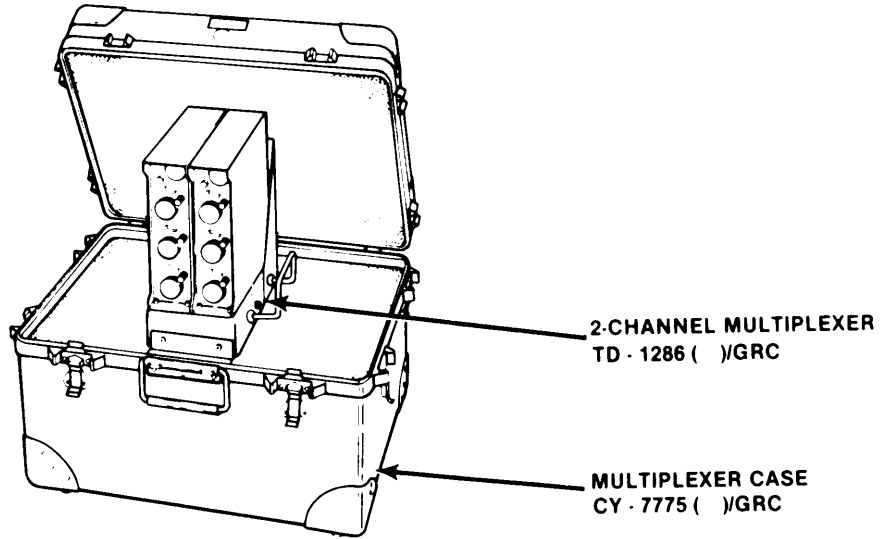

I 2-CHANNEL MULTIPLEXER AND MULTIPLEXER CASE

Multiplexer Case CY-7776 ()/GRC: The Multiplexer Case CY-7776 ()/GRC provides housing for all three versions of the 5-channel multiplexer, i.e., TD-1289 () (V)1/GRC, TD-1289 () (V)2/GRC and TD-1289 () (V)3/GRC.

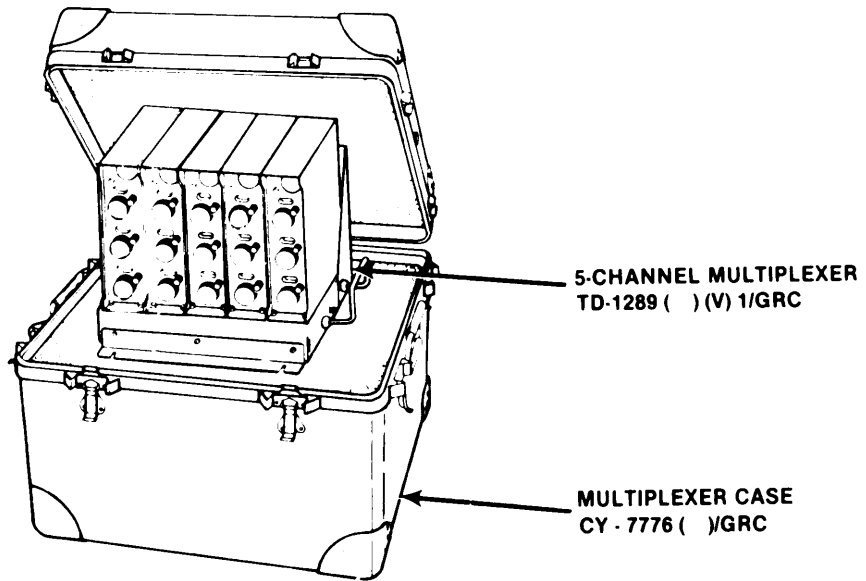

J 5 - CHANNEL MULTIPLEXER AND MULTIPLEXER CASE

SECTION III

PRINCIPLES OF OPERATION

1-12 MECHANICAL AND ELECTROMECHANICAL OPERATION.

a. 2-Channel Multiplexer TD-1288 ()/GRC and 5-Channel Multiplexer TD-1289 () (V)/GRC. Receives and isolates rf energy from transceiver(s) and couples this energy to the broadband antenna.

b. Forward Reflected Power Discriminator. Takes a sample of the rf energy transmitted through the multiplexer and determines the magnitude of forward and reflected power.

c. Input Coupling and Resonator/Central Resonator/Output Resonator and Coupling. Provides rf coupling and frequency selectivity by means of manually tuned resonators. An rf sample is also sent to the 90° phasing discriminator by means of the central resonator.

d. Coupling Network. Matches the 7-ohm resistive load of the band-pass filter to a 50-ohm resistive load of the antenna and optimizes the VSWR across the operating frequency range.

e. 90° Phasing Discriminator. Determines the magnitude of the phase relationship of the rf energy passing through the multiplexer.

f. 60W Power Level/6W Power Level. A resistive network that allows a full scale meter reading of 60W or 6W on the front panel meter.

g. Meter Function Switch. Selects phase, reflected power, and forward power at a 60W or 6W level.

h. Meter. Displays function selected by meter function switch.

i. **Tuning Knobs.** Three tuning knobs used for coarse and rf tuning of band-pass filter.

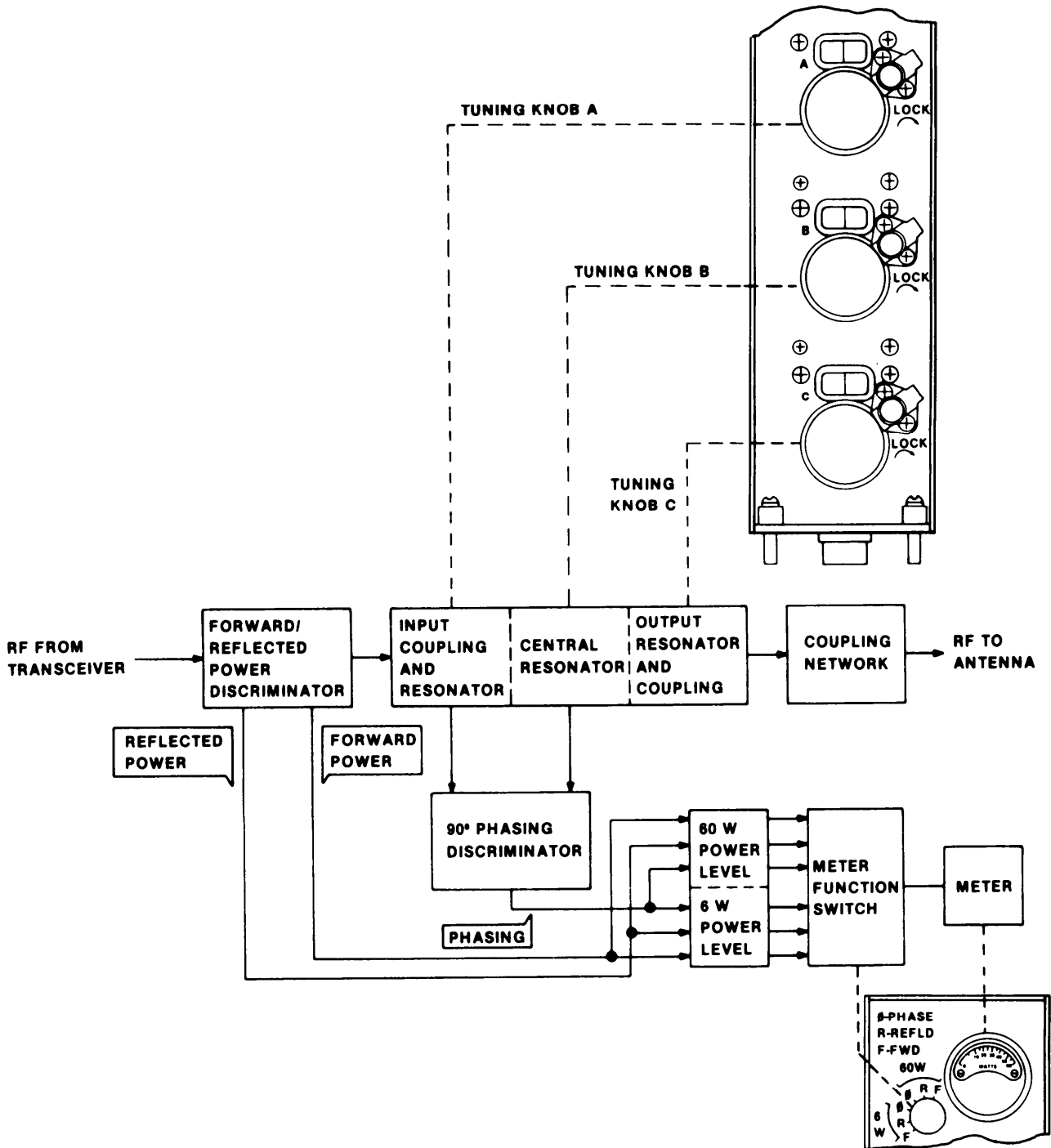

1-13 ELECTRICAL AND ELECTRONIC OPERATION.

a. **Forward/Reflected Power Discriminator.** The forward and reflected power discriminators operate in a similar manner, therefore the reflected power discriminator will be discussed first with additional comments about the forward power discriminator discussed last.

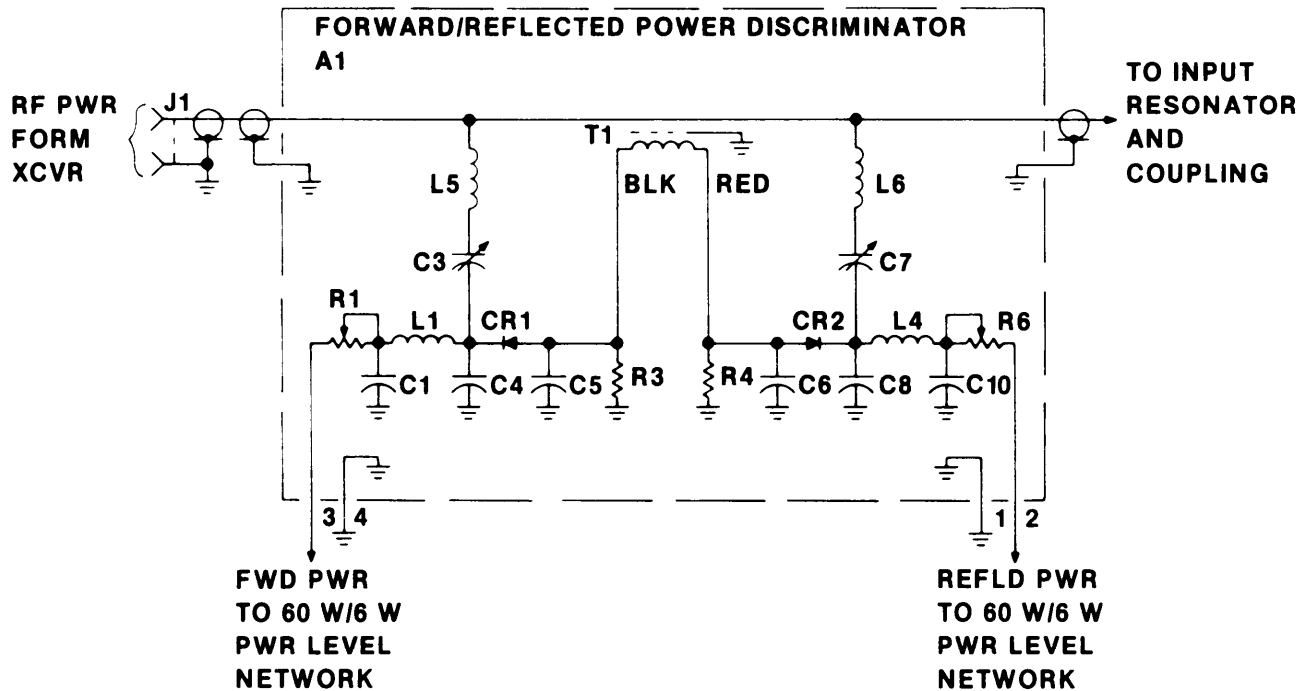

A current sample is taken from rf line by transformer T1. This provides a voltage across load resistor R4 proportional to the line current. This voltage is applied to the anode of diode CR2. At the same time, a voltage sample is applied to the cathode end of the diode (derived by capacitor divider C7 and C8). The transformer phasing and circuit constants are set so that when the rf line is terminated in its characteristic impedance (50 ohms) the two samples are equal in phase and magnitude. Therefore, diode CR2 does not conduct and the reflected power output is zero. Any deviation from the terminated impedance of 50-ohms causes the balance to be out of equilibrium and diode CR2 conducts in proportion to the unbalance. The dc output voltage diode CR2 is proportional to the reflected power and is sent to the 60W/6W power level network for eventual monitoring by the front panel meter.

The forward power discriminator functions the same as the reflected power discriminator except the current and voltage sample are 180° out of phase. This results in a dc output voltage being at maximum when the rf line is terminated in 50-ohms. Any other value of terminating impedance will cause the dc output voltage to vary proportional to forward power, thereby causing the monitored voltage to change.

b. Input Coupling and Resonator/Central Resonator/Output Resonator and Coupling. The input coupling employs a fixed series inductor (L7) tapped into the input resonator (L8 and C12). This form of coupling provides good coupling characteristics along with minimum resonator frequency shift. The resonator circuit is composed of inductor L8 and variable capacitor C12. The variable capacitor is mechanically linked to the top tuning knob on the front panel. The tuning knob is used for selecting operating frequency and for coarse and rf tuning adjustments. The resonator also supplies a voltage sample to the 90° phasing discriminator. The resonator also supplies a voltage sample to the 90° phasing discriminator.

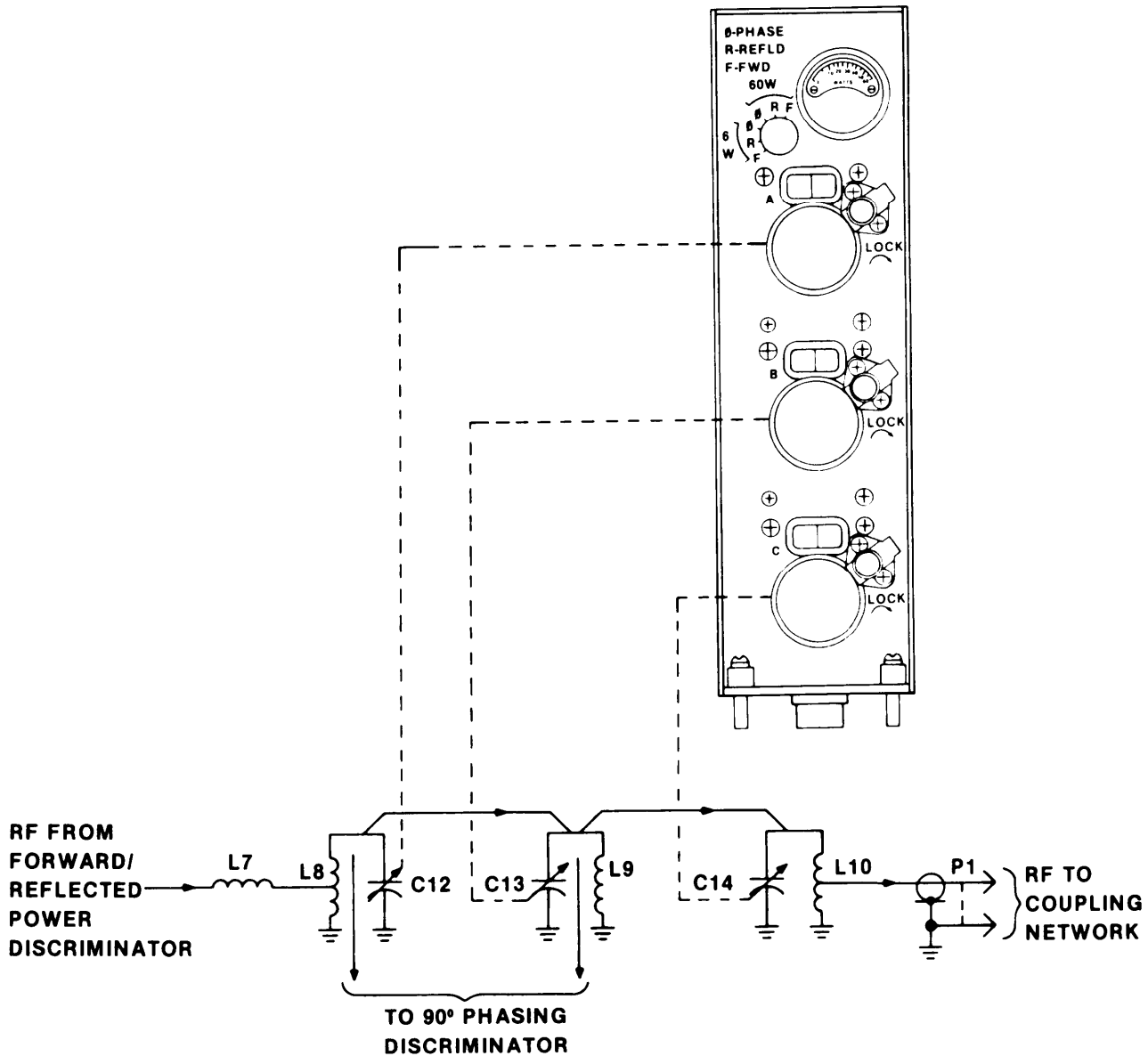

The central resonator is composed of inductor L9 and variable capacitor C13. The variable capacitor is mechanically linked to the center tuning knob on the front panel. The tuning knob is used for selecting operating frequency and for coarse and rf tuning adjustment. The resonator also supplies a voltage sample to the 90° phasing discriminator.

The output resonator and coupling is composed of variable capacitor C14 and tapped inductor L10. The variable capacitor is mechanically linked to the lower tuning knob on the front panel. The tuning knob is used for selecting operating frequency and for coarse and rf tuning adjustments. Tapped coupling of inductor L10 provides a 7-ohm resistive load to the coupling network.

c. Coupling Network. The coupling network translates the 7-ohm resistive load of the output resonator and coupling to a 50-ohm resistive load (antenna impedance) and provides a reactance canceling network to optimize the VSWR across the operating frequency range. The divider network configuration determines the resistance transformation and the values of the components determine the optimization of the VSMR. Capacitor C1 is a compensating capacitor that has a value determined by the number of channels comprising the multiplexer.

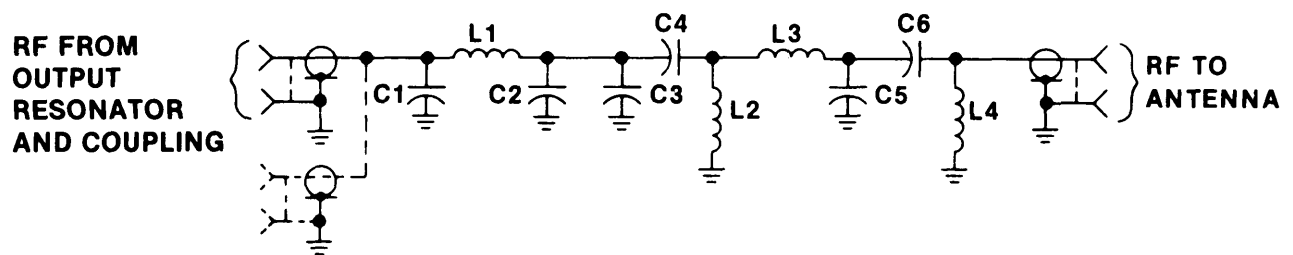

d. 90° Phasing Discriminator, 60W/6W Power Level Network, Meter Function Switch and Meter. The 90° phasing discriminator is fed by two voltage sample inputs, one from the coupling and resonator and the second from the central resonator. Voltage sample V_1 appears in the secondary of transformer T3 as two equal voltages but 180° out of phase with respect to the center tap. The second voltage sample V_2 is coupled to the center tap of transformer T3 through transformer T2. Therefore, when V_1 and V_2 have a 90° phase relationship, the dc voltage appearing across potentiometer R9 is equal in magnitude and opposite in polarity with respect to the wiper of potentiometer R9. The total voltage across the potentiometer is zero. As the phase relationship of voltage V_1 and V_2 change, the total voltage across potentiometer R9 is either positive or negative depending on whether V_1 leads or lags V_2 by more or less than 90°. The magnitude depends on how greatly the angle between V_1 and V_2 differ. A bridge rectifier is connected to the output of the discriminator. This provides unidirectional voltage output for the metering circuitry. For example, the output voltage of the bridge circuit is zero for a 90° phase relationship between V_1 and V_2 and positive going for any deviation from 90° between the two voltage samples. The dc voltage is then sent on to the 60W/6W power level network.

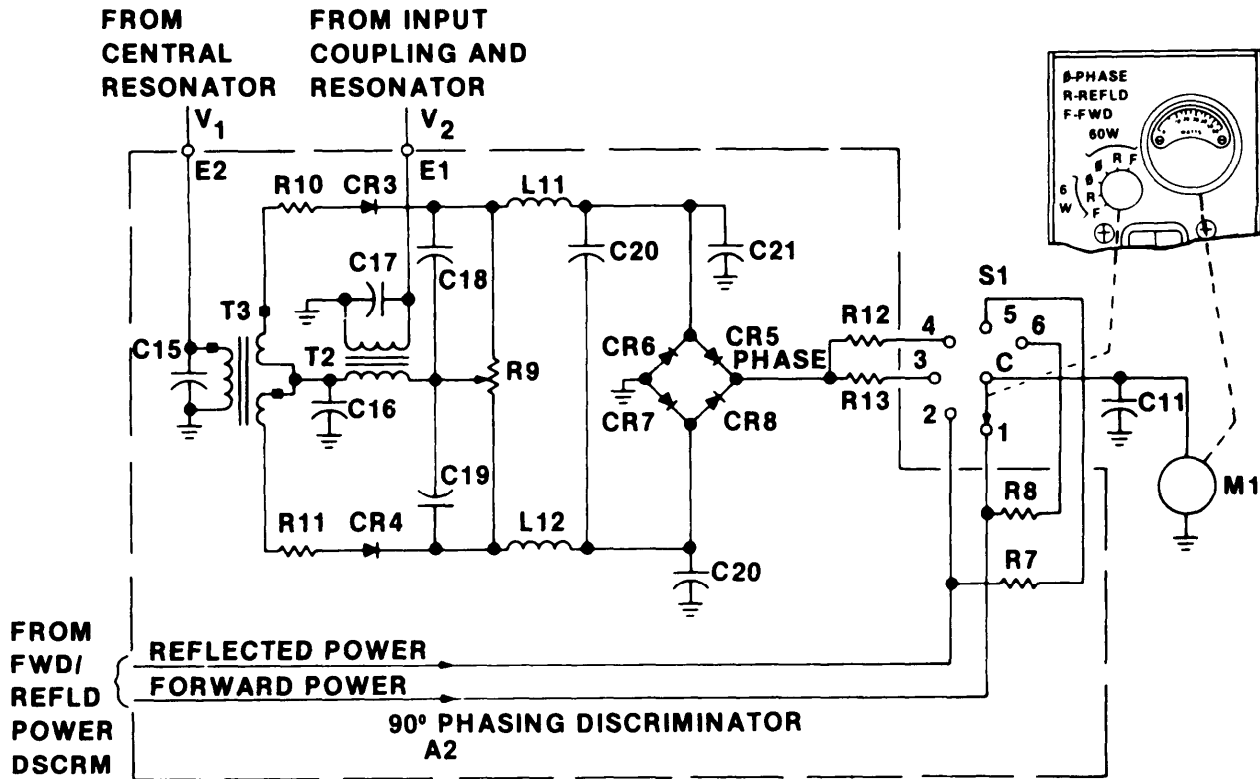

e. 60W/6W Power Level Network. The 60W/6W power level network consisting of resistors R7, R8, R12, and R13 provide the values needed to give a voltage ratio equivalent to 60W: 6W for metering.

f. Meter Function Switch S1. The meter function switch S1 located on the front panel selects forward power, reflected power, and phasing at a 60W level or a 6W level. The output is then sent to the meter.

g. Meter M1. Meter M1 has two scales. One is a 60W scale and the other a 6W scale. The scale used is determined by the meter function switch located on the front panel. Meter movement corresponds to the meter function switch position.

CHAPTER 2

OPERATING INSTRUCTIONS

SECTION I

DESCRIPTION AND USE OF OPERATOR'S CONTROLS, INDICATORS, AND CONNECTORS

2-1 METER FUNCTION SWITCH SETTING.

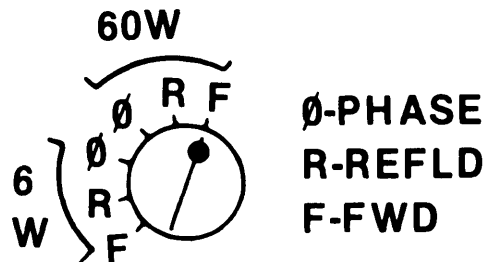

60W: The 60 watt section is used for rf tuning of the band-pass filter.

60W-F: The 60 watt-forward position is for high-level forward power through the band-pass filter. This can be used to display high-level transceiver rf power output on the meter.

60W-R: The 60 watt-reflected position is for high-level reflected power through the band-pass filter. This position is used for rf tuning of band-pass filter knobs A, B, and C.

60W-Ø: The 60 watt-phase position is for high-level phase error in the band-pass filter. This position is used during rf tuning of the band-pass filter in order to phase knob B.

6W: The 6 watt section is used for rf fine tuning of the band-pass filter after the 60 watt rf tuning of the band-pass filter is completed or for rf tuning of the band-pass filter using a low-level transceiver.

6W-Ø: The 6 watt-phase position is for low-level phase error in the band-pass filter. This position is used during rf tuning of the band-pass filter in order to phase knob B.

6W-R: The 6 watt-reflected position is for low-level reflected power through the band-pass filter. This position is used at end of 60 watt tuning procedure of the band-pass filter because it allows rf fine tuning of knobs A, B, and C while passing high-level reflected power through the band-pass filter. This position is also used for rf tuning of the band-pass filter when using low-level transceivers.

6W-F: The 6 watt-forward position is for low-level forward power through the band-pass filter. This can be used to display low-level transceiver rf power output not exceeding 6 watts.

2-2 TUNING KNOBS A, B, AND C.

Tuning knobs A, B, and C are identical. They are used to coarse tune the selected frequency in the window (bisected by a hairline). When rf tuning with the meter, they are adjusted for minimum reflected power and zero phase through the band-pass filter. The lock knobs are each turned counterclockwise to unlock the tuning knobs and turned clockwise finger tight to lock the tuning knobs when tuning is completed.

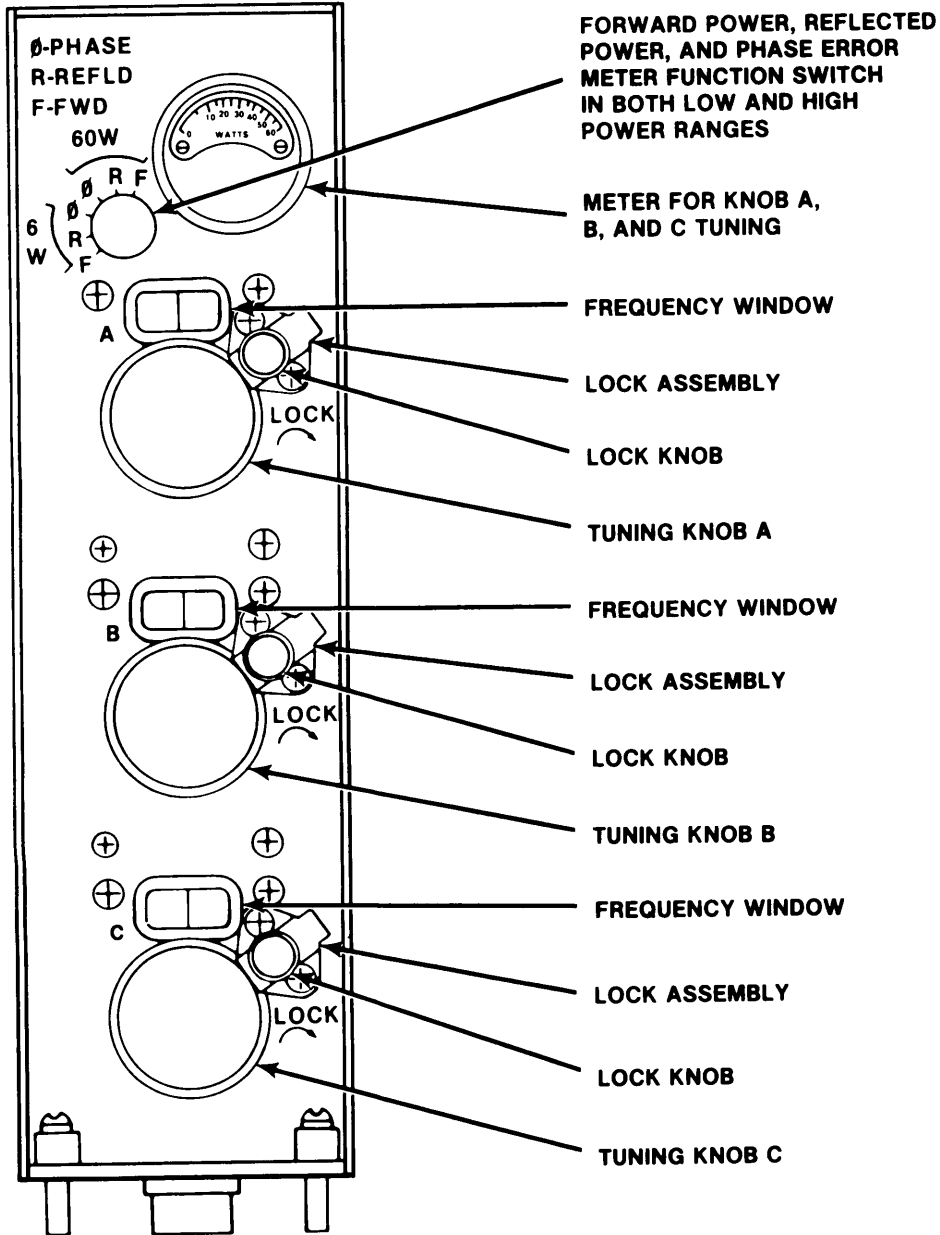

**BANDPASS FILTER F - 1482()/GRC
(FRONT VIEW)**

2-3 METER.

The meter is used to indicate forward power, reflected power, and phase error through the band-pass filter. The meter function switch will determine the function of the meter. When selecting 60W-F on the meter function switch, the rf output of the transceiver passing through the band-pass filter is displayed up to 60 watts. When selecting 60W-R on the meter function switch, tuning knobs A, B, and C are used to rf tune the band-pass filter, and the meter will indicate the proper tune points when the displayed power is minimum. When selecting 60W-Ø on the meter function switch, tuning knob B is used to rf tune high-level phase error in the band-pass filter, and the meter will indicate the proper tune point when the displayed power is 0. When selecting 6W-F, 6W-R, or 6W-Ø on the meter function switch, meter indications will be the same as for 60W positions. Remember that the 6W positions are used for rf fine tuning of the band-pass filter after 60W rf tuning or for rf tuning of the band-pass filter using low-level transceivers with rf power not exceeding 6 watts.

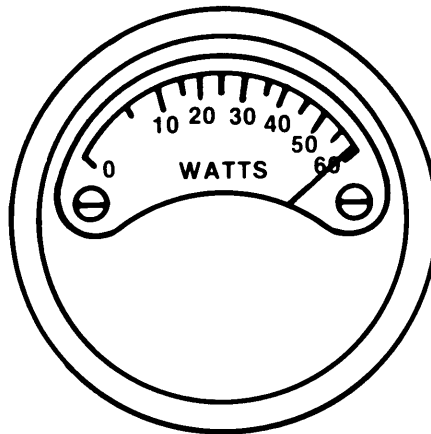

In the 2-channel multiplexer, which uses two transceivers and one antenna, a coaxial (coax), such as RG-58 or equivalent, is connected from the antenna receptacle of one transceiver to the coax receptacle on the rear of either band-pass filter. The coax from the second transceiver antenna receptacle is then connected to the coax receptacle on the rear of the other band-pass filter. The coax, such as RG-213 or equivalent, from the antenna output connector on the coupler is connected to the AS-3166 (part of OE-254/GRC group) wide-band antenna or equivalent. The 5-channel multiplexer hookup is similar to the 2-channel hookup except that the 5-channel uses from three to five transceivers.

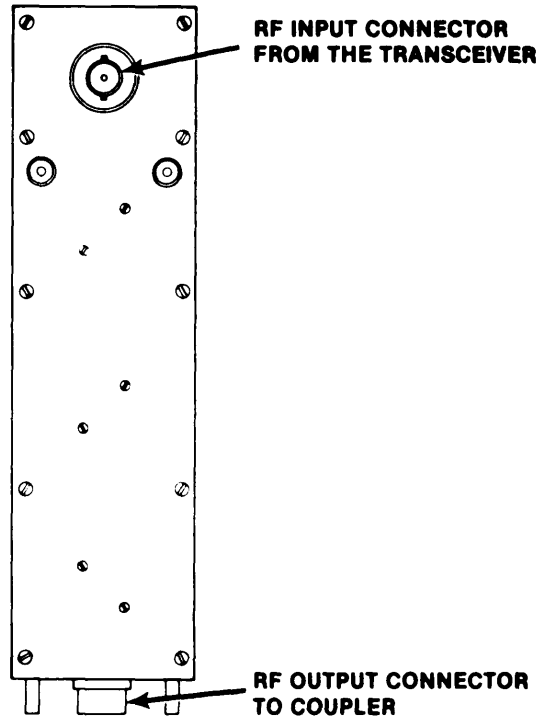

**BAND-PASS FILTER F - 1482 ()GRC
(REAR VIEW)**

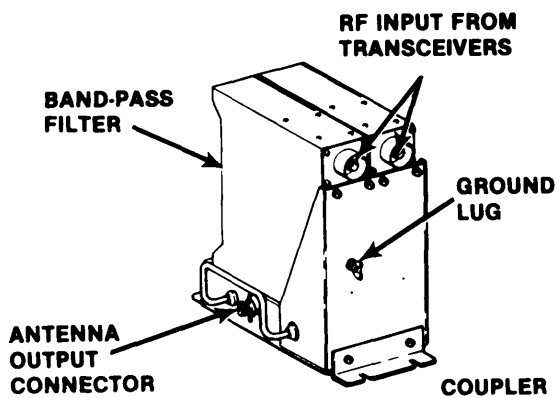

**2 - Channel Multiplexer
TD - 1288 ()GRC (Rear View)**

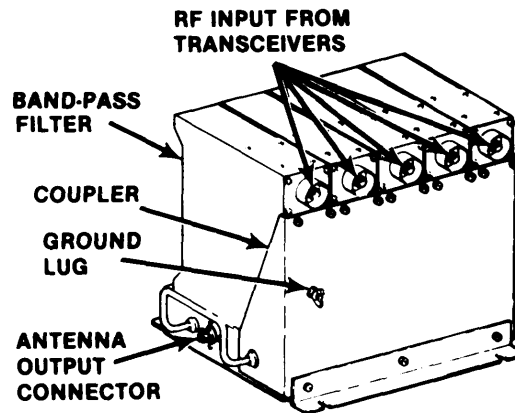

**5 - Channel Multiplexer
TD - 1289 () (V) 1/GRC (Rear View)**

SECTION II

OPERATION UNDER USUAL CONDITIONS

WARNING

Before assembling the multiplexer, turn off the power switches of all transceivers and auxiliary receivers in the system.

CAUTION

Do not lay the multiplexer on its back or handle side. This may cause damage to the rf connector, ground lug, or handle. Stand it up.

When removing the band-pass filter from the coupler, pull straight up to avoid damage to the rf connector on the bottom of the band-pass filter or its mating rf connector on the coupler. When carrying a multiplexer, use the handle. When transporting a multiplexer, use the multiplexer case.

WARNING

Insure couplers, band-pass filters, and termination units in all vacant filter jacks are securely connected. Loose connections can cause rf burns.

2-5 ASSEMBLY.

Assembly of the 2-channel multiplexer is similar to the 5-channel multiplexer, the difference being in the number of band-pass filters and termination units.

a. Coupler CU-2266 ()/GRC and CU-2267 ()/GRC. Check the band-pass filter mating connectors and antenna connector on the coupler, and make sure they are clean. Check the ground lug on the rear of the coupler, and make sure that it isn't damaged. Secure the coupler by installing four mounting bolts.

b. Band-pass Filter F-1482()/GRC. Check the rf connector on the bottom of the band-pass filter, and make sure it is clean. rf connector on the coupler and then gently pressing the filter straight down. After insertion, secure the band-pass filter with four screws.

NOTE

When any of the filters in the 5-channel multiplexer are not being used, replace the band-pass filters with a termination unit as presented in c below or set rest frequency of unused band-pass filters 5 percent removed from any operating frequencies.

c. **Termination Unit MX010080 ()/GRC.** Check the rf connector on the bottom of the terminal unit, and make sure it is clean. Install the termination unit by first positioning it over the mating rf connector on the coupler and then gently pressing the termination unit straight down. After insertion, secure the termination unit with two captive screws.

NOTE

When one of the band-pass filters in the 2-channel multiplexer or four of the band-pass filters in the 5-channel multiplexer are not being used, remove the multiplexer and connect the transceiver rf output directly to the antenna. When three of the band-pass filters in the 5-channel multiplexer are not being used, replace with a 2-channel multiplexer or temporarily replace the three band-pass filters with termination units, thereby creating an unauthorized 2-channel configuration; or temporarily operate with the unused band-pass filters 5 percent removed in frequency.

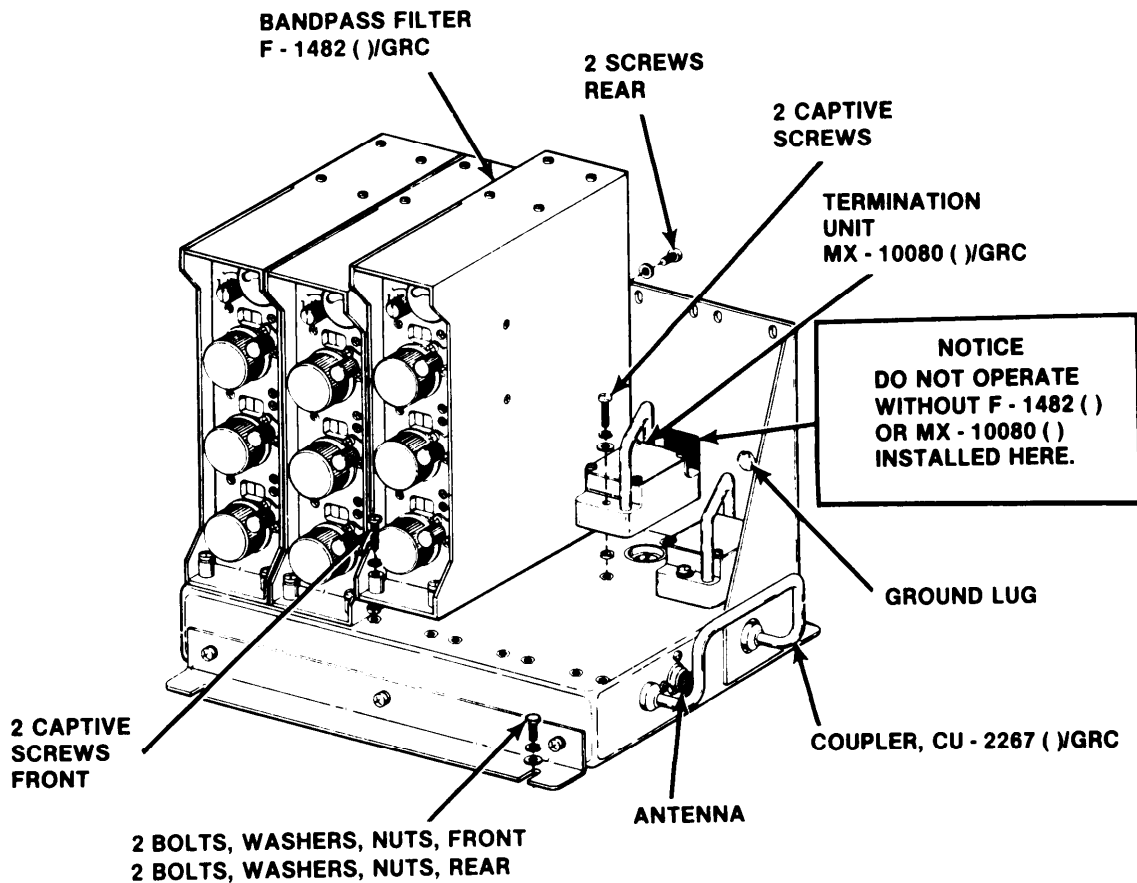

2-6 PREPARATION FOR USE.

- a. First obtain your assigned operating and alternate frequencies.
- b. Be sure that all coaxes and multiplexer are secure and properly assembled. Refer to paragraph 2-7 for operating procedures.

WARNING

Insure all transceivers have their power source grounds joined together at the multiplexer ground lug before connecting coax cables. Connect an earth ground to the multiplexer ground lug.

- c. Be sure that termination units are plugged into all vacant band-pass filter connectors on the coupler prior to applying rf power.

CAUTION

The coarse tuning section of the tuning procedure must be performed before the transceiver is keyed. Complete the rf tuning within approximately 1 minute. The caution note in the procedure covers this.

2-7 OPERATING PROCEDURE.

- a. Preliminary Checks. Prior to tuning, check the following conditions:
 - (1) No other filters are tuned to, or within 5 percent of the frequency about to be used. Refer to frequency tuning wheel.
 - (2) Rf power input to each band-pass filter will not exceed a nominal 60 watts.
 - (3) The antenna connector of the coupler must be connected to a 50-ohm broadband antenna such as AS-3166 (part of the OE-254/GRC antenna group).

CAUTION

To avoid equipment damage, do not key the transceiver during paragraph **b** (coarse tuning) of this procedure.

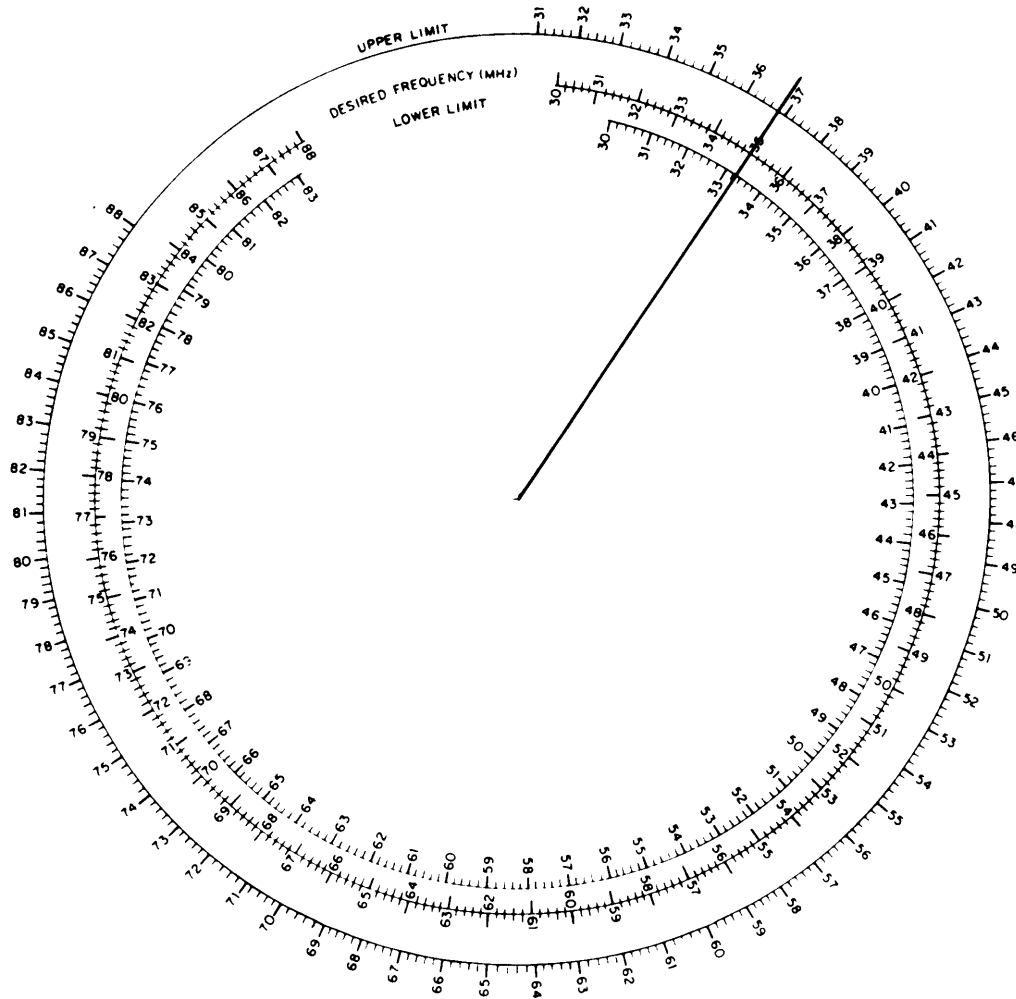

Frequency Tuning Wheel

- (a) Find the frequency to be tuned on the desired frequency scale.
- (b) Draw a line from the center through the selected frequency.
- (c) Read upper limit frequency on upper limit scale.
- (d) Read lower limit frequency on lower limit scale.
- (e) For example: Use 35 MHz as the desired frequency, upper limit is 36.75 and lower limit is 33.25. No other filter must be tuned between these limits.

b. Goarse Tuning Before Applying Rf Power:

- (1) Unlock tuning knobs A, B, and C by turning lock knobs counterclockwise.

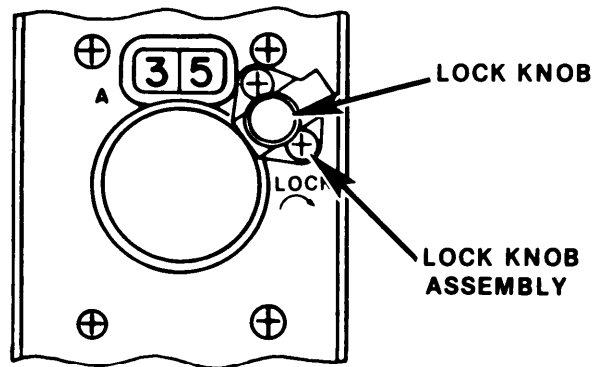

- (2) Using tuning knobs A, B, and C, set the first two numbers of the desired frequency in the center of each of the dial windows.

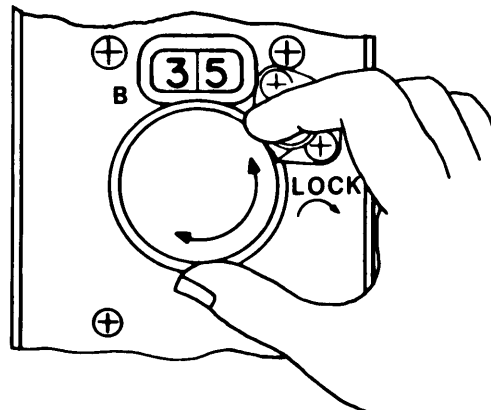

- (3) Set the meter function switch to the 60 watt (60W) reflected power (R) position.

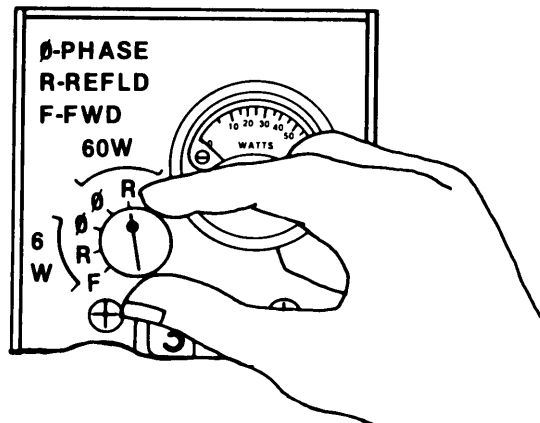

c. Rf Tuning After Applying Rf Power.

NOTE

The objective of using these tuning procedures is to bring the meter needle on the band-pass filter to zero and have it remain there when the transceiver is keyed.

CAUTION

To avoid equipment damage, complete rf tuning steps 1 through 5 within approximately 1 minute.

(1) Key the transceiver continuously to apply rf power while tuning.

(2) Adjust tuning knob A for minimum reflected power as indicated by a minimum reading on meter. Adjust tuning knob B, and then tuning knob C, for a minimum reflected power.

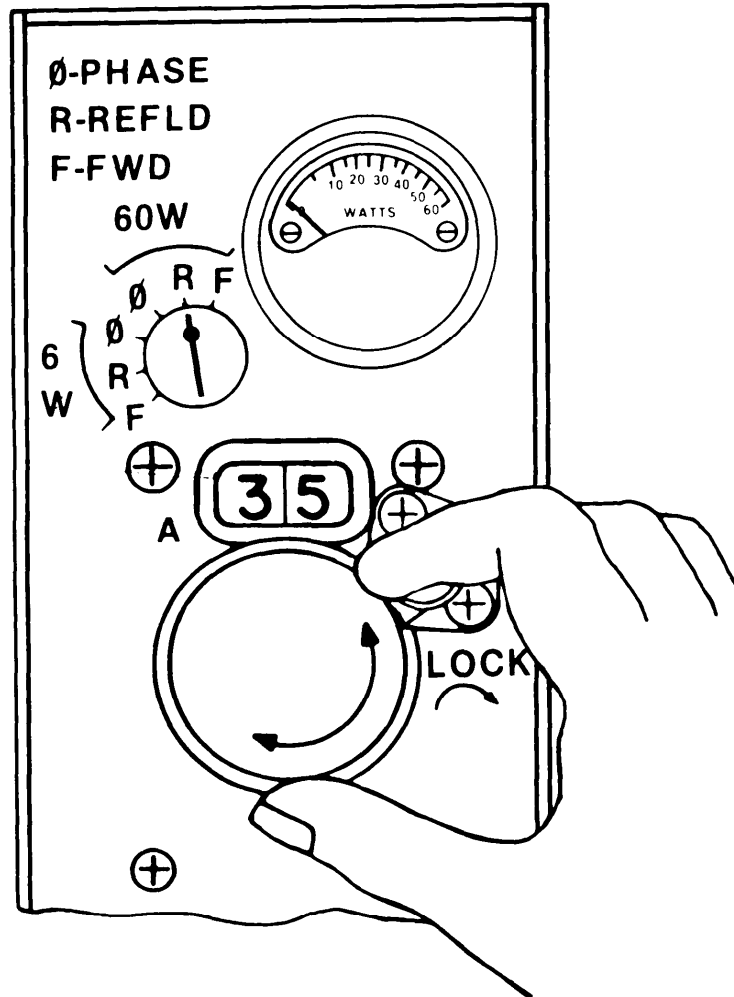

(3) Set the meter function switch to 60 watt (60W) phase (\emptyset) position. Adjust tuning knob B for zero phase error.

NOTE

Zero phase error will be indicated by a zero reading on the meter with a very sharp up-scale deflection on either side of the zero point.

(4) Return the meter function switch to the 60W-R position. Readjust tuning knobs A and C for minimum reflected power.

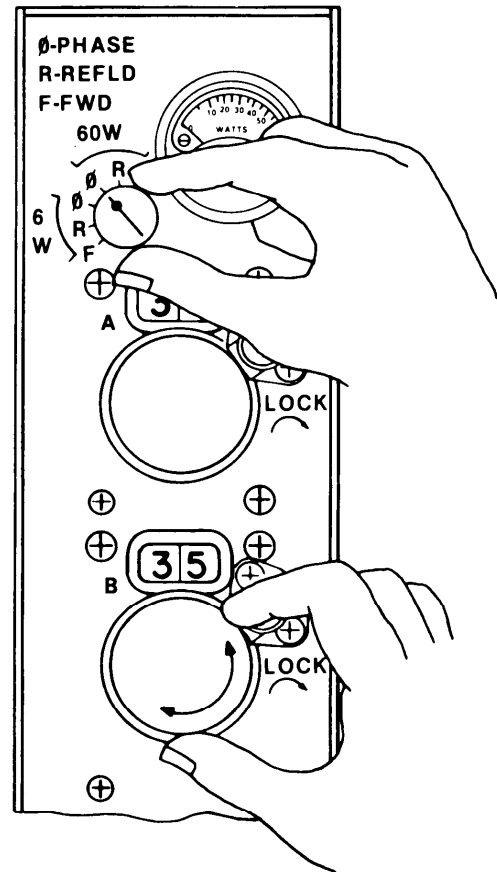

(5) Repeat 3 and 4 above until the lowest reflected power and zero phase error are attained. Tuning knob B in phase (\emptyset) position should be the final adjustment.

(6) Set the meter function switch to the 6 watt (6W) reflected power (R) position. If you have an indication of zero on the meter, proceed to 9 below. Readjust tuning knobs A and C for minimum reflected power.

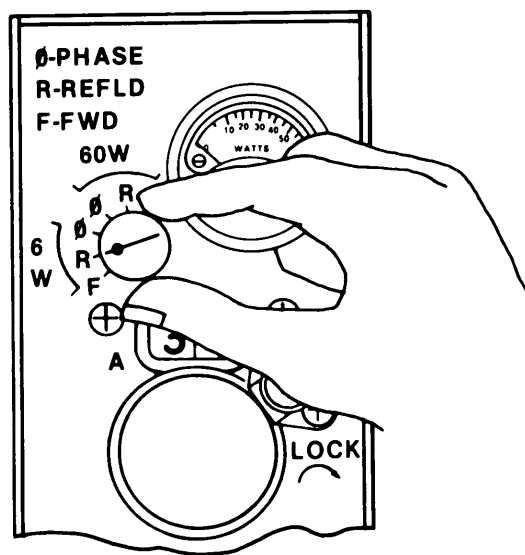

(7) Set the meter function switch to the 6 watt (6W) phase (Ø) position. Adjust tuning knob B for zero phase error.

(8) Repeat 6 and 7 above until the lowest reflected power and zero phase error are attained. Tuning is complete. Unkey the transceiver.

(9) Lock the three tuning knobs with a finger-tight rotation of the lock knobs. Do not use tools.

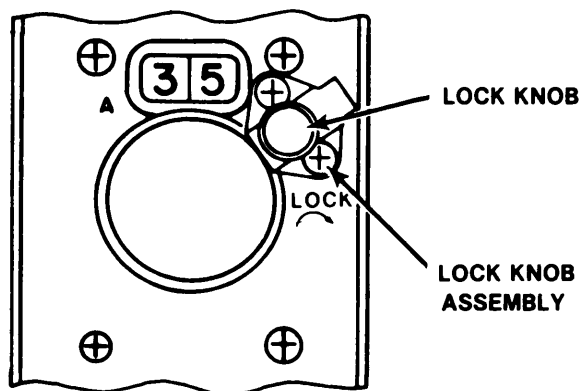

CAUTION

When in the 6W-F position, do not exceed 6 watts of input power. You could peg the meter if you exceed these input levels.

(10) Turn off rf power at transceiver.

(11) The following conditions indicate an untuned band-pass filter.

Set the meter function switch to 60W-F.
Meter indication similar to 60W-R.

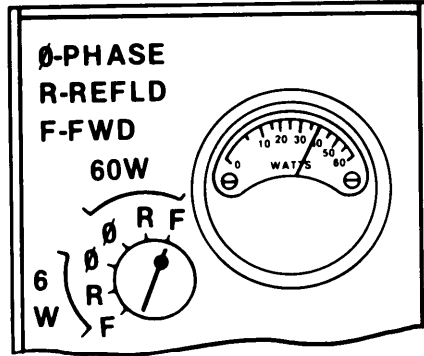

Set the meter function switch to 60W-R.
Meter indication similar to 60W-F.

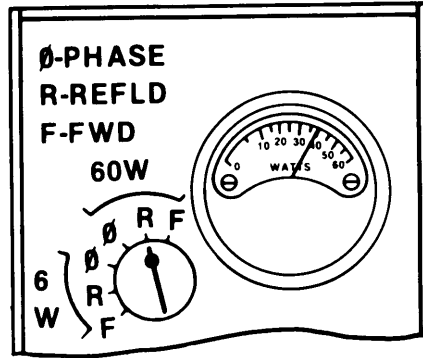

Set the meter function switch to 60W-Ø.
Meter indicates 0 or low reading.

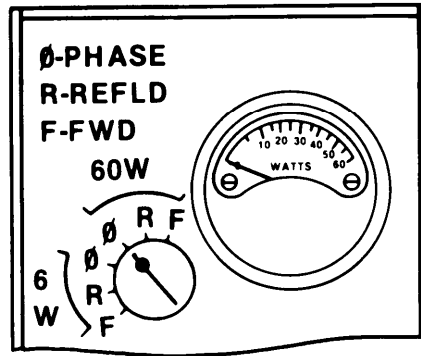

CAUTION

If the above meter conditions are indicated, do not check meter function switch positions in the 6W range. You could peg the meter.

(12) The following conditions indicate a tuned band-pass filter.

Set the meter function switch to 60W-F.
Meter indicates 0 to 60 watts.

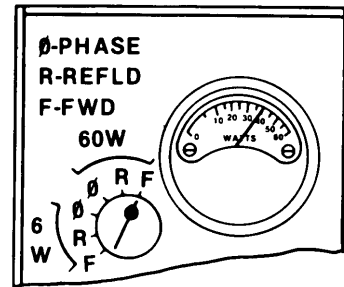

Set the meter function switch to 60W-R.
Meter indicates a low reading.

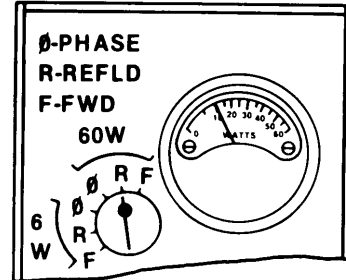

Set the meter function switch to 60W-Ø.
Meter indicates 0.

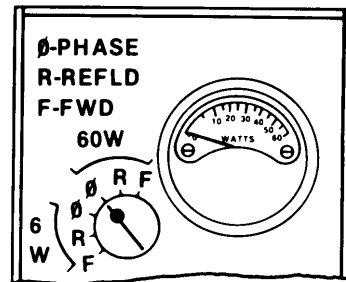

Set the meter function switch to 6W-Ø.
Meter indicates 0.

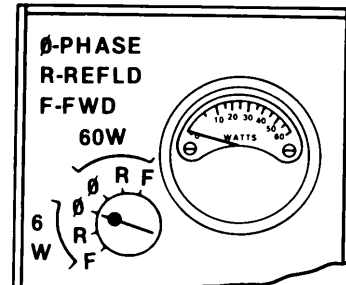

Set the meter function switch to 6W-R.
Meter indicates a low reading.

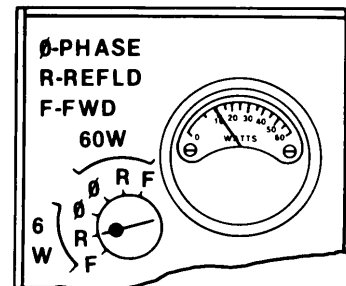

CAUTION

Do not check meter function switch 6W-F when using high power transceivers. You could peg the meter. Use meter function switch position 6W-F only when using transceivers with 6 watts or less of power output.

SECTION III

OPERATION UNDER UNUSUAL CONDITIONS

2-8 OPERATION AT LOW TEMPERATURES.

Keep the multiplexer front panel controls and meter free of ice so that the control shafts can be turned. Do not use sharp objects to remove ice. Do not bend your cables suddenly.

2-9 OPERATION IN DESERT AND DUSTY AREAS.

When operated in desert or dusty climates, large amounts of sand and dust may collect on the multiplexer. Keep the multiplexer as clean as possible. In the case of extreme dust or sand storms, cover equipment for protection.

2-10 OPERATION IN RAIN, HIGH HUMIDITY, OR SALT FOG.

Keep equipment as clean and dry as possible. In the case of extreme rain, high humidity, or salt fog, cover equipment for protection. When your mission is completed, clean as thoroughly as possible.

2-11 FORDING.

The multiplexer, in its transit case, is able to withstand fording rivers and streams. When your mission is completed, clean as thoroughly as possible.

CHAPTER 3

OPERATOR MAINTENANCE INSTRUCTIONS

SECTION I INTRODUCTION

3-1 GENERAL.

This chapter contains operator maintenance instructions for the TD-1288 ()/GRC and TD-1289 ()/GRC multiplexers. There are no tools Or test equipment required for operator maintenance. Do not go beyond the instructions given in this chapter.

SECTION II LUBRICATION

3-2 GENERAL.

There are no lubrication requirements for the multiplexers.

SECTION III OPERATOR'S PREVENTIVE MAINTENANCE

3-3 GENERAL.

Preventive maintenance is the systematic care, servicing, and inspection of equipment to prevent occurrence of trouble, to reduce downtime, and to ensure that the equipment is performing to its maximum operational capability. Preventive maintenance includes inspection and checking of the equipment on a regularly scheduled basis.

3-4 OPERATOR PREVENTIVE MAINTENANCE CHECKS AND SERVICES (PMCS).

The following instructions apply to the operator PMCS procedures listed in table 3-1.

NOTE

When doing any PMCS or routine checks, keep in mind the warnings and cautions listed in the front of this manual.

- a. BEFORE OPERATION, perform the (B) PMCS.
- b. DURING OPERATION, observe the performance of the equipment related to the (D) PMCS.
- c. AFTER OPERATION, perform the (A) PMCS.
- d. If the equipment was not used during the week, perform the (B), (D), and (A) PMCS together the (W) PMCS.
- e. If the equipment fails to operate, try troubleshooting (refer to 3-6). If the equipment is damaged, report it using the proper forms. See TM 38-750 for instructions.
- f. The Item No. column in table 3-1 shall be used as a source of item numbers for the TM Number column on DA Form 2404 (Equipment Inspection and Maintenance Worksheet) in recording the results of the PMCS.
- g. If the multiplexers are scheduled for administrative storage (1 to 45 days), perform the PMCS immediately after removing from storage.

NOTE

The PROCEDURES column in your PMCS chart instructs you to “check and have repaired or adjusted as necessary.” Carefully follow these instructions, and if tools are needed or the chart instructions tell you, get organizational maintenance to do the necessary work.

If your equipment must be in operation all the time, check and service only those items that can be checked and serviced without disturbing operation. Make the complete checks and services when the equipment can be shut down.

3-5 SPECIAL INSTRUCTIONS.

Routine checks like cleaning, dusting, washing, stowing items not in use, covering unused receptacles, and checking for loose nuts and bolts are not listed as PMCS checks. They are things that should be done when deemed necessary.

WARNING

Insure all transceivers have their power source grounds joined together at the multiplexer ground lug before connecting coax cables. Connect an earth ground to the multiplexer ground lug.

Insure couplers, band-pass filters, and termination units in all vacant filter jacks are securely connected. Loose connections can cause rf burns.

Table 3-1. Operator Preventive Maintenance Checks and Services

NOTE

The checks in the interval column are to be performed in the order listed.

B = Before Operation D n During Operation A = After Operation W = Weekly M - Monthly

Item No.	Interval					Item to be Inspected	Procedures check and have repaired or adjusted as necessary	Equipment is not ready/ available if:
	B	D	A	W	M			
						Multiplexer	<p>NOTE Procedures apply to both the 2-channel and the 5-channel multiplexer.</p>	
1	*		*				Check to see that the coupler is mounted securely.	
2	*		*				Check to see that the band-pass filters and/or termination units are mounted securely.	
3	*		*				Check the ground lug on the rear of the coupler.	Loose or damaged.
4	*		*				Check all ground straps, and be sure that they are in place, tight, and in good condition.	
5	*		*			Controls, switches, and knobs	Check for broken knobs and lock knobs.	Any of the three tuning or lock knobs are broken or missing.
6	*		*				Check for broken meter unctions switch knob.	Knob is broken or missing.
7	*		*				Check to see that all tuning knobs, meter function switches, and lock knobs move through their required motion without application of excessive force.	
8	*		*				Check to see that knobs are securely attached to the shafts of switches and controls.	
9	*		*				Check to see that the meter function switches are oriented on their shafts so that they indicate the proper setting at each position.	

Table 3-1. Operator Preventive Maintenance Checks and Services (Continued)

Item No.	Interval					Item to be Inspected	Procedures check and have repaired or adjusted as necessary	Equipment is not ready/ available if:
	B	D	A	W	M			
10	*		*				Check to see that all switches and controls stop at their limits unless they are intended to rotate continuously.	
11	*		*			Meters, indicators, and limits.	Check the glass covers of all meters and frequency dial windows; be sure that they are not cracked or loose.	Broken glass.
12	*		*				Check for condensed moisture on the inside of glass meter covers. This is an indication of inadequate sealing of the equipment, inadequate ventilation, or both.	Fogged glass
13	*		*				Check to see that glass meter covers and frequency dial windows are not discolored. Wipe off any grease, oil, moisture, or other foreign matter that may have accumulated on the outer surface of the glass.	Meter not visible.
14	*		*				Check to see that all meter function switches are in their specified positions before turning on power. (After rf tuning, should be in 60W-F position.)	
15	*	*	*				Check all meters to see that the indicating needles are intact and straight and that the needles move as they should. Check the movement of the needle when the set is turned on or when changes during operation affect the indication of the meter.	Meter needle defective.
16	*		*			Cables and connectors	Check to see that all cables are in good condition, clean, dry, and placed where they will not be damaged during normal operation.	
17	*		*				Check to see that cables are not stretched taut, have no kinks or tight bends (especially near the connectors), are not pulled tight against sharp edges or corners of equipment cases, are not under pressure caused by items placed upon them or leaned against them, and are not subjected to excessive heat or direct sunlight.	

Table 3-1. Operator Preventive Maintenance Checks and Services (Continued)

Item No.	Interval					Item to be Inspected	Procedures check and have repaired or adjusted as necessary	Equipment is not ready/ available if:
	B	D	A	W	M			
18	*		*			Multiplexer operation	Check upper rear rf coax connector on the band-pass filter for dents or damage.	Damaged or dented rf coax connector.
19	*		*		Check antenna rf connector on side of coupler for damage.			
20	*		*		Check to see that all connectors are in good condition and tightly connected to proper receptacles.			
21	*		*		Wipe off any grease, oil, moisture, or other foreign matter from cables and connectors.			
22	*	*	*	*	With the transceiver turned on and set to the tune frequency of the band-pass filter through which it is to transmit, and with all the other band-pass filters tuned to their assigned frequencies, key the transceiver and talk to a distant station.			
23	*	*	*		Observe the meter for correct deflection when the transceiver is keyed. Check the output from the transceiver by placing the meter function switch in the 60W-F position. Observe the meter for 60 watts.			

SECTION IV TROUBLESHOOTING

3-6 GENERAL

The troubleshooting table lists the common malfunctions that you may find during the operation or maintenance of the 2-channel or 5-channel multiplexer. You should perform the test, inspections, and corrective actions in the order listed.

This manual cannot list all malfunctions that may occur, nor all tests or inspections and corrective actions. If a malfunction is not listed or is not corrected by listed corrective actions, notify your supervisor.

WARNING

Shut off or disconnect all transceivers before performing maintenance or troubleshooting on any part of the multiplexer.

Table 3-2. Troubleshooting

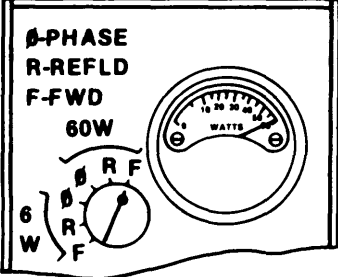
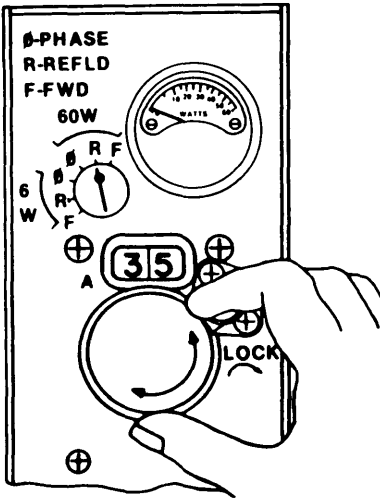
Step	Operation	Normal indication	Corrective procedure
1	<p>Provided the band-pass filter is tuned to the transceiver frequency, check rf power output of the transceiver. Set the band-pass filter meter function switch to 60W-F.</p>  <p style="text-align: center;">Forward power output 35 to 60 watts for the VRC-12 family.</p>		<p>If rf power output is 0, check coax connectors from the transceiver to the multiplexer. If power output is still 0, refer to the transceiver operator's manual.</p>
2	<p>Observe the meter during tuning. Set band-pass filter meter function switch to 60W-R.</p>  <p style="text-align: center;">Reflected power output is low.</p>		<p>If the tuning meter indicates a high reading during tuning or the meter movement does not go to a minimum, check the multiplexer and antenna coax connections. If this does not solve the problem, refer to organizational maintenance for a replacement band-pass filter.</p>

CHAPTER 4

ORGANIZATIONAL MAINTENANCE INSTRUCTIONS

SECTION I INTRODUCTION

4-1 GENERAL.

The organizational maintenance instructions for the TD-1288 ()/GRC and TD-1289 () (V)/GRC multiplexer contained in this chapter cover the corrective actions authorized to be performed by the organizational level technician. The organizational maintenance concept is to isolate a fault to a module and replace the module with a known operational one. The organizational level technician is also responsible for the installation of the multiplexer in a fixed and/or mobile site. Do not go beyond the instructions given in this chapter.

SECTION II REPAIR PARTS, TOOLS, AND TEST EQUIPMENT

4-2 REPAIR PARTS.

Repair parts are listed and illustrated in the repair parts and special tools list, TM 11-5820-880-20P.

4-3 TOOLS AND TEST EQUIPMENT.

Tools and test equipment required for organizational maintenance are listed in appendix B of this manual.

SECTION III SERVICE UPON RECEIPT

4-4 SITING AND SHELTER REQUIREMENT.

There are no special siting and shelter requirements for the multiplexers. Reference should be made to the associated transceivers technical manuals.

4-5 UNPACKING.

No special sequence of action is necessary to protect the equipment when unpacking.

4-6 CHECKING UNPACKED EQUIPMENT.

a. Inspect the equipment for damage incurred during shipment. If the equipment has been damaged, report the damage on SF 364, Report of Discrepancy.

b. Check the equipment against the packing slip to see if the equipment is complete. Report all discrepancies in accordance with the instructions of TM 38-750.

c. Check to see whether the equipment has been modified.

SECTION IV INSTALLATION INSTRUCTIONS

4-7 TOOLS, TEST EQUIPMENT, AND MATERIALS REQUIRED FOR INSTALLATION.

- a. Drill and drill bits.
- b. Pencil.
- c. Mounting bolts, nuts, and washers (type dependent upon material used for mounting).
- d. Wrenches and Phillips screwdriver.

4-8 ASSEMBLY OF EQUIPMENT.

Refer to paragraph 2-5 for assembly instructions.

4-9 INSTALLATION PROCEDURES.

WARNING

All connections for intervehicular installations must be made prior to applying power. It is important that all transceivers operated from separate power sources and to be connected to a single multiplexer have their power source grounds joined together before connecting coax cables. The joined power source grounds must be connected to the ground lug of the multiplexer. Examples of separate power sources are separate vehicles, separate AC generators, and separate AC line connected power supplies. As an example of compliance with the above requirement, the vehicle grounds of vehicular powered transceivers would be joined together and connected to the ground lug of the multiplexer. It is recommended that an earth ground be connected to the multiplexer ground lug. This earth ground will eliminate any induced potentials and help protect personnel from lightning discharges.

a. Installation of 2-Channel Multiplexer TD-1288 ()/GRC.

When the 2-channel multiplexer is to be installed in a permanent location, perform the following steps:

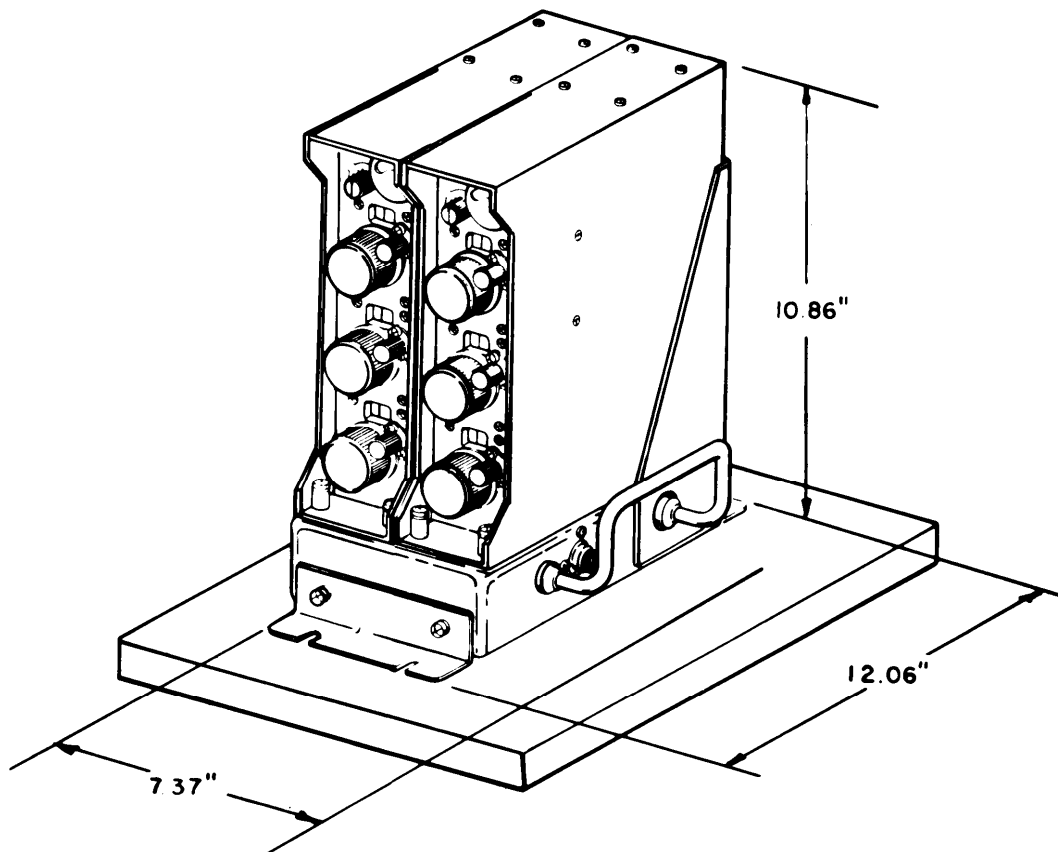

- (1) Be sure the location is adequate in size. Minimum size is 7.37 in. W x 12.06 in. D x 10.86 in. H.
- (2) Place multiplexer in location desired.
- (3) Mark mounting surface for holes to be drilled.
- (4) Remove multiplexer and drill holes in mounting surface to accommodate bolts.
- (5) Install multiplexer with 4 bolts, nuts, and washers.
- (6) Connect ground wires to ground lug of the coupler.
- (7) Connect coaxial cables RG-58 or equivalent from transceiver(s) to the band-pass filters.
- (8) Connect coaxial cable RG-213 or equivalent from antenna connector on the coupler to the antenna.

b. Installation of 5-Channel Multiplexer TD-1289 () (V)/GRC.

When the 5-channel multiplexer is to be installed in a permanent location, perform the following steps:

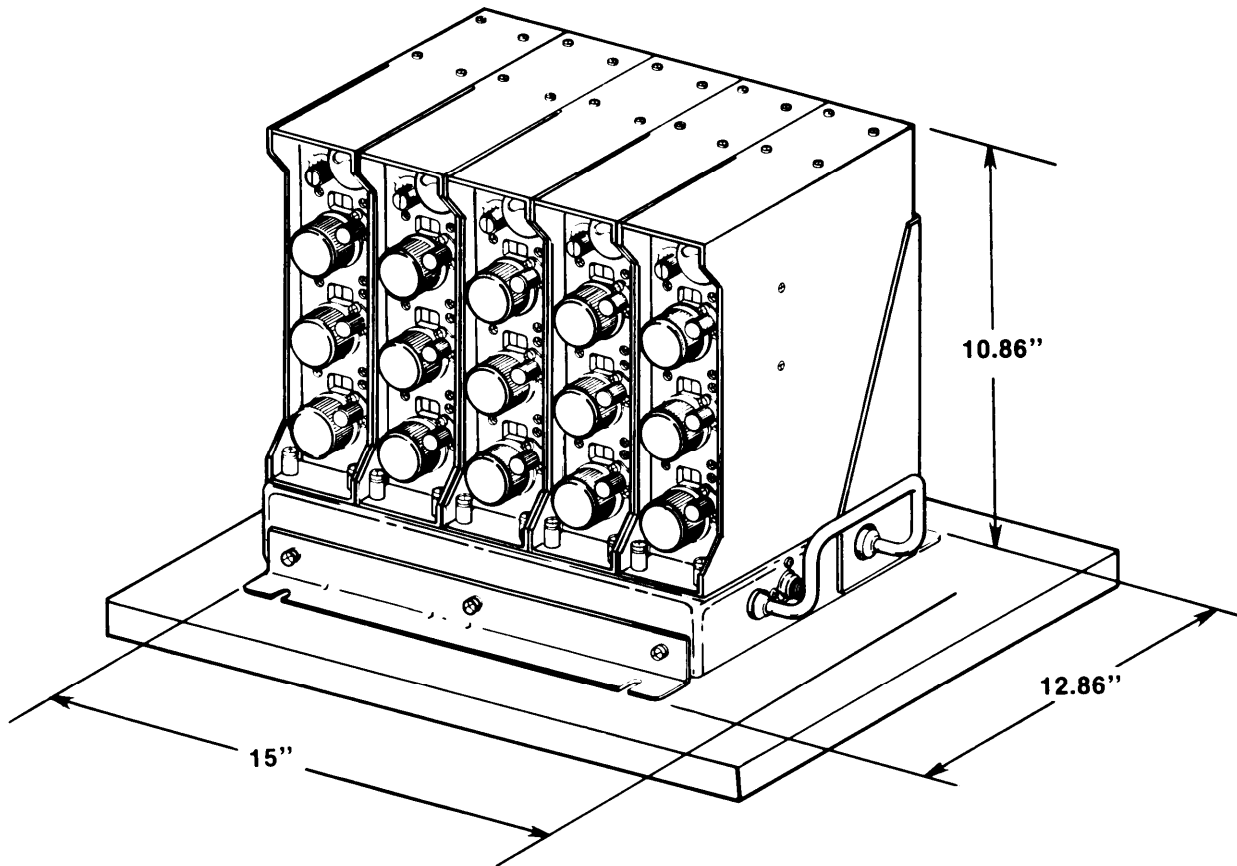

- (1) Be sure the location is adequate in size. Minimum size is 15 in. W x 12.06 in. D x 10.86 in. H.
- (2) Place multiplexer in location desired.
- (3) Mark mounting surface for holes to be drilled.
- (4) Remove multiplexer and drill holes in mounting surface to accommodate bolts.
- (5) Install multiplexer with 4 bolts, nuts, and washers.
- (6) Connect ground wires to ground lug of the coupler.
- (7) Connect Coaxial Cables RG-58 or equivalent from transceiver(s) to the band-pass filters.
- (8) Connect Coaxial Cable RF-213 or equivalent from antenna connector on the coupler to the antenna.

c. Cable Connections for the 2-channel Multiplexer TD-1288 ()/GRC and 5-Channel Multiplexer TD - 1289() (V)/GRC.

WARNING

When connecting transceiver rf coax cables to the multiplexer, make sure the transceivers are turned off.

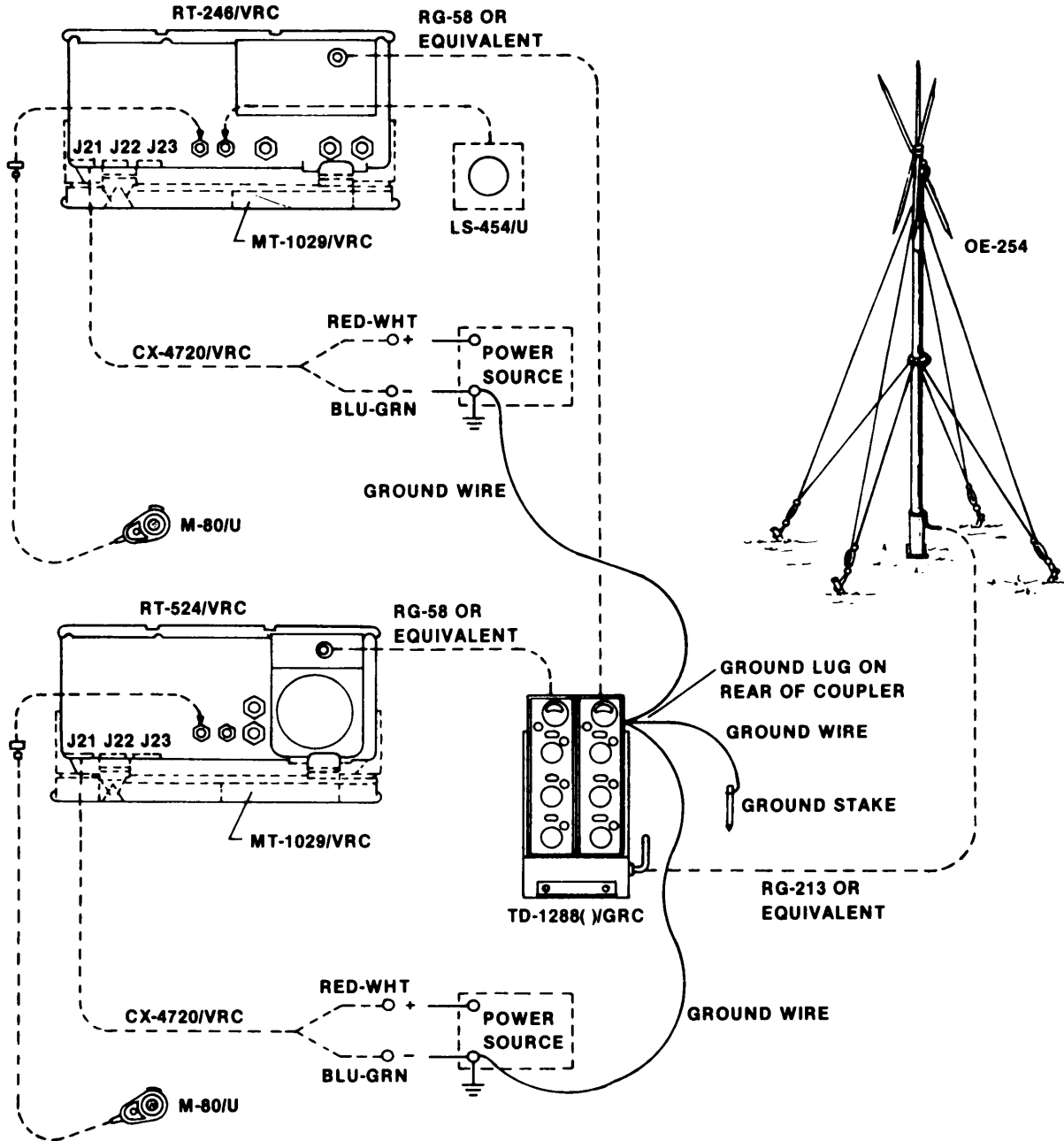

4-10 OPERATIONAL CHECKS.

Perform the operating procedures as described in paragraph 2-7.

WARNING

All connections for intervehicular installations must be made prior to applying power. It is important that all transceivers operated from separate power sources and to be connected to a single multiplexer have their power source grounds joined together before connecting coax cables. The joined power source grounds must be connected to the ground lug of the multiplexer. Examples of separate power sources are separate vehicles, separate AC generators, and separate AC line connected power supplies. As an example of compliance with the above requirement, the vehicle grounds of vehicular powered transceivers would be joined together and connected to the ground lug of the multiplexer. It is recommended that an earth ground be connected to the multiplexer ground lug. This earth ground will eliminate any induced potentials and help protect personnel from lightning discharges.

SECTION V ORGANIZATIONAL PREVENTIVE MAINTENANCE

4-11 GENERAL.

- a. Refer to Chapter 3 for an introduction to preventive maintenance.
- b. Organizational preventive maintenance is performed on a quarterly basis.

4-12 ORGANIZATIONAL PREVENTIVE MAINTENANCE CHECKS AND SERVICES (PMCS).

The following instructions apply to the organizational PMCS procedures listed in table 4-1.

- a. If the equipment fails to operate try troubleshooting (para 4-13). If the equipment is damaged, report it using the proper forms. See TM 38-750 for instructions.
- b. The Item No. column in table 4-1 shall be used as a source of item numbers for the TM Number column on DA Form 2404 (Equipment Inspection and Maintenance Worksheet) in recording the results of the PMCS.

NOTE

If the equipment must be in operation all the time, check and service only those items that can be checked and serviced without disturbing operation. Make the complete checks and services when the equipment can be shut down.

**Table 4-1. Organizational Preventive Maintenance Checks and Services
Quarterly Schedule**

Item No.	Item to be inspected	Procedures
1	Publications	Check to see that associated transceiver organizational maintenance manuals are on hand, including latest changes.
2	Equipment Modifications	Check to see whether modification work orders (MWOs) that are required have been or are scheduled to be performed.
3	Multiplexer Case CY-7775 ()/GRC, 2-channel CY-7776 ()/GRC, 5-channel	<ul style="list-style-type: none"> a. Check to see that the metal surfaces are free of rust and corrosion. b. Check for water tightness.
4	Coupler CU-2266 ()/GRC, 2-channel CU-2267 ()/GRC, 5-channel	<ul style="list-style-type: none"> a. Check to see that the metal surfaces are free of rust and corrosion. b. Check connectors for cleanliness and damage. c. Check for water tightness. d. Check the ground lug on the rear of the coupler for damage.
5	Band-pass Filter F-1482 ()/GRC	<ul style="list-style-type: none"> a. Check to see that the metal surfaces are free of rust and corrosion. b. Check to see that tuning knobs or selectors turn smoothly, and are not damaged or missing. c. Check for water tightness. d. Check meter face for broken or cracked glass or signs of possible damage, such as being fogged e. Check connectors for cleanliness and damage.
6	Termination Unit MX-10080 ()/GRC	<ul style="list-style-type: none"> a. Check to see that the metal surfaces are free of rust and corrosion. b. Check for water tightness. c. Check connector for cleanliness and damage.

SECTION VI TROUBLESHOOTING

4-13 GENERAL.

This section provides troubleshooting data (see table 4-2) for use in isolating problems detected by organizational personnel during in-place operation of the multiplexer. If faults cannot be isolated as described in this section, maintenance must be referred to higher echelon maintenance personnel.

Table 4-2. Troubleshooting

Indication	Corrective Action
No meter indication on any function.	<ul style="list-style-type: none"> a. Check cable from transceiver to multiplexer. Look for poor connection or badly worn cable. b. Check to see that the transceiver is on.
Meter movement is erratic.	Check cable connections. Look for loose connection or faulty connectors.
Meter movement will not go to a minimum.	Check frequency separation of $\pm 5\%$ with other band-pass filters.
Meter indication for forward power and reflected power the same.	<ul style="list-style-type: none"> a. Check antenna coax cables and antenna. b. Check for proper tuning. c. Check frequency separation of $\pm 5\%$ with other band-pass filters.
Meter movement forward power is not within 10% of transceiver output power after tuning.	<ul style="list-style-type: none"> a. Check coax from transceiver to band-pass filter. b. Check for proper tuning. c. Check frequency separation of $\pm 5\%$ with other band-pass filters.

SECTION VII

MAINTENANCE PROCEDURES

4-14 GENERAL.

The following maintenance procedures are the responsibility of the organizational maintenance technician. For maintenance that is required but not in this section, refer to depot support maintenance.

4-15 REMOVAL AND INSTALLATION.

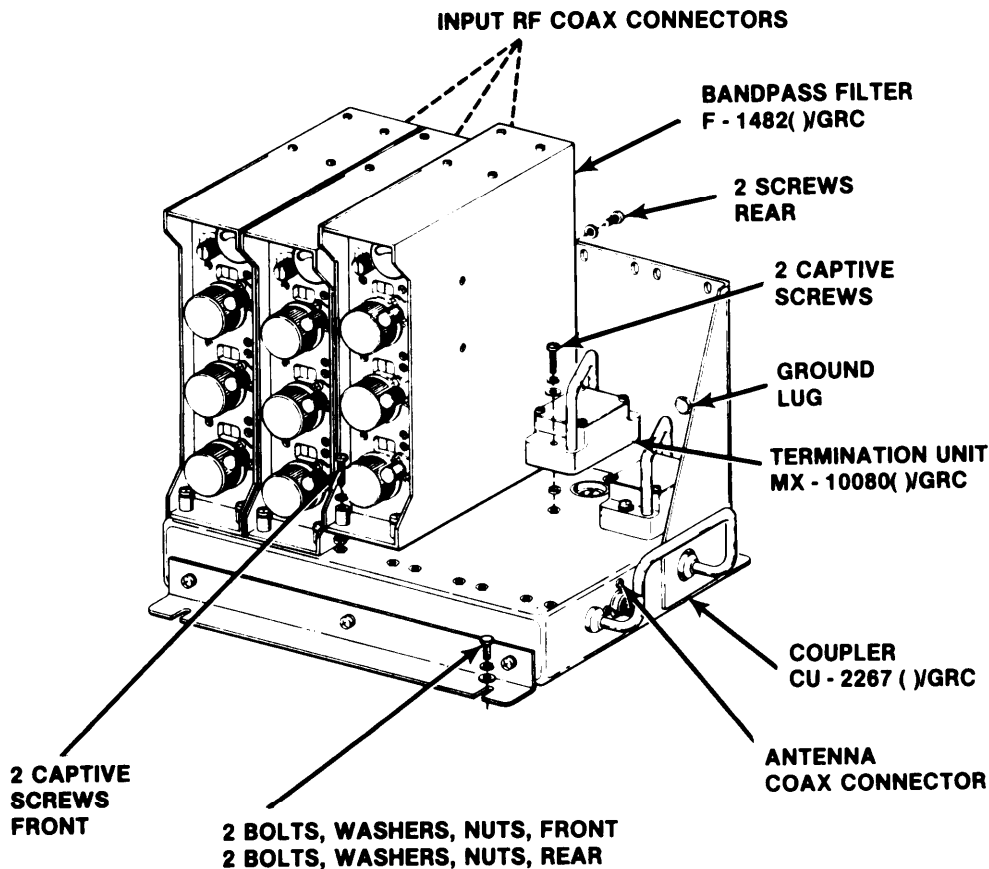

a. Termination Unit.

- (1) Unkey all transceivers so that all rf input power is removed from the multiplexer.
- (2) Loosen the two (2) captive screws that secure the termination unit to the coupler.
- (3) Remove the termination unit by pulling straight up, using the termination unit handle, until separated.
- (4) To install a replacement termination unit, reverse the above procedure.
- (5) Perform the operating procedures described in paragraph 2-7.

b. Band-pass Filter.

- (1) Unkey all transceivers so that all rf input power is removed from the multiplexer.
- (2) Disconnect the rf coax cable from connector J1 at the rear of the band-pass filter.
- (3) Loosen four (4) screws and two (2) captive screws in the front, and two (2) screws in the rear that secure the band-pass filter to the coupler.
- (4) Remove the band-pass filter by pulling it straight up until separated.
- (5) To install a replacement band-pass filter, reverse the above procedure.
- (6) Perform the operating procedures described in paragraph 2-7.

c. Coupler.

- (1) Unkey all transceivers so that all rf input power is removed from the multiplexer.
- (2) Remove the coax cables from all band-pass filter inputs.
- (3) Remove the coax cable from the antenna connector on the coupler.
- (4) Remove the wires attached to the ground lug at the rear of the coupler.
- (5) Remove the four (4) bolts that hold the coupler to the mounting surface. Two (2) bolts are located in the front and two (2) in the rear.
- (6) Loosen four (4) screws and two (2) captive screws in the front, and two (2) screws in the rear of each band-pass filter.
- (7) Remove each band-pass filter by pulling it straight up until separated.
- (8) Loosen the two (2) captive screws that secure each termination unit to the coupler.
- (9) Remove the termination unit by pulling straight up, using the termination unit handle, until separated.
- (10) Install the termination units in the replacement coupler.
- (11) Install the band-pass filters in the replacement coupler.
- (12) To install a replacement coupler to the mounting surface, reverse the above procedure.
- (13) Perform the operating procedures described in paragraph 2-7.

d. Tuning Knob and Lock Knob.

- (1) Unkey all transceivers so that all rf input power is removed from the multiplexer.
- (2) Loosen the lock knob by turning it counterclockwise.
- (3) Remove two (2) screws holding the lock knob assembly to front panel of band-pass filter.
- (4) Remove the lock knob assembly.
- (5) Loosen two (2) set screws on the tuning knob with Allen wrench.
- (6) Pull off the tuning knob.
- (7) To install a replacement tuning knob and lock knob assembly, reverse the above procedure.
- (8) If removing the lock knob only, turn it counterclockwise until removed from threaded shaft on the lock knob assembly.
- (9) To install a replacement lock knob, reverse the above procedure.

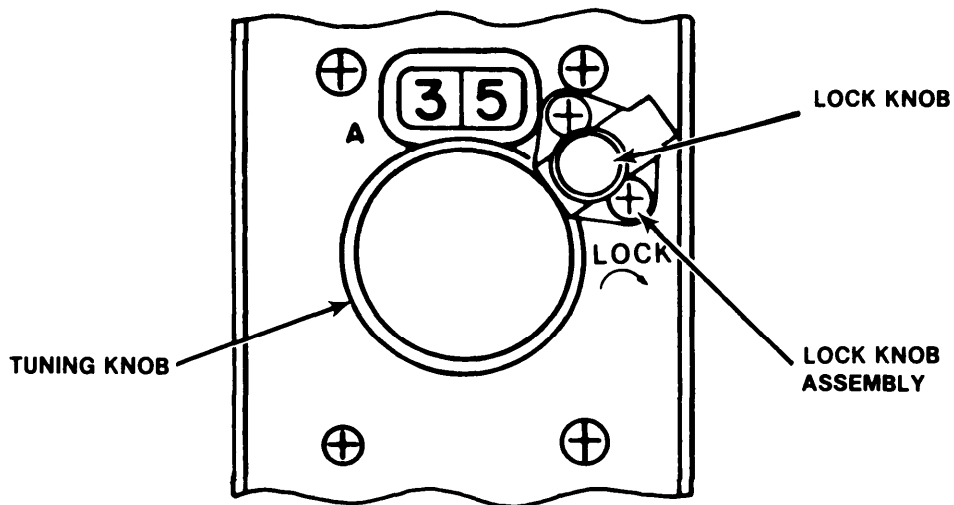

4-16 CLEANING.

The exterior surfaces of the equipment should be free of dust, dirt, grease, oil, or fungus.

- a. Remove dust and loose dirt with a clean cloth.

WARNING

Adequate ventilation should be provided while using TRICHLORO-TRIFLUOROETHANE. Prolonged breathing of vapor should be avoided. The solvent should not be used near heat or open flame; the products of decomposition are toxic and irritating. Since TRICHLORO-TRIFLUOROETHANE dissolves natural oils, prolonged contact with skin should be avoided. When necessary, use gloves which the solvent cannot penetrate. If the solvent is taken internally, consult a physician immediately.

- b. Remove grease, oil, fungus, and ground-in dirt from the equipment with a cloth dampened (not wet) with cleaning compound.
- c. If the equipment is washed using a water hose, do not direct the water directly at the front panels of the band-pass filters or at cable connectors. Wipe the equipment after using the water hose and let sit until dry.

4-17 PAINTING.

For touch-up painting of bare metal surfaces, first remove rust and corrosion from metal surfaces with fine sandpaper. Brush two thin coats of paint onto the bare metal to protect it from further corrosion.

APPENDIX A

REFERENCES

- DA Pam 310-1 Consolidated Index of Army Publications and Blank Forms.
- DA Pam 310-10-2 The Standard Army Publications System (STARPUBS): Resupply Guide.
- SB 38-100 Preservation, Packaging, Packing and Marking Materials, Supplies, and Equipment Used by the Army.
- TB 43-0118 Field Instructions for Painting and Preserving Electronics Command Equipment Including Camouflage Pattern Painting of Electrical Equipment Shelters.
- TB 43-180 Calibration Requirements for the Maintenance of Army Materiel.
- TM 11-5820-401-12 Operator's and Organizational Maintenance Manual for Radio Sets, AN/VRC-12 (NSN 5820-00-223-7412), AN/VRC-43 (5820-00-223-7415), AN/VRC-44 (5820-00-223-7417), AN/VRC-45 (5820-00-223-7418), AN/VRC-46 (5820-00-223-7433), AN/VRC-47 (5820-00-223-7434), AN/VRC-48 (5820-00-223-7435), AN/VRC-49 (5820-00-223-7437), AN/VRC-54 (5820-00-223-7567); Mounting Kit, MT-1029/VRC (5820-00-893-1323) and MT-1898/VRC (5820-00-893-1324); Antenna Kit, AT-912/VRC (5820-00-897-6357); Control, Frequency Selector, C-2742/VRC (5820-00-892-3343) and Control, Radio Set, C-229/VRC (5820-00-892-3340).
- TM 11-5820-880-20P Organizational Maintenance Repair Parts and Special Tools List for Transceiver Multiplexer TD-12881GRC (NSN 5820-01-090-1414), TD-1289(V)1/GRC (5820-01-090-5407), TD-1289(V)2/GRC and TD-1289(V)3/GRC.
- TM 11-5985-357-13 Operator's, Organizational, and Direct Support Maintenance Manual for Antenna Group, OE-254/GRC (NSN 5985-01-063-1574).
- TM 38-750 The Army Maintenance Management System (TAM MS).
- TM 740-90-1 Administrative Storage of Equipment.
- TM 750-244-2 Procedures for Destruction of Electronics Materiel to Prevent Enemy Use (Electronics Command).

APPENDIX B

MAINTENANCE ALLOCATION

SECTION I

INTRODUCTION

B-1 GENERAL.

This appendix provides a summary of the maintenance operations for the multiplexer. It authorizes categories of maintenance for specific maintenance functions on repairable items and components and the tools and equipment required to perform each function. This appendix may be used as an aid in planning maintenance operations.

B-2 MAINTENANCE FUNCTION.

Maintenance functions will be limited to and defined as follows:

- a. Inspect.** To determine the serviceability of an item by comparing its physical, mechanical, and/or electrical characteristics with established standards through examination.
- b. Test.** To verify serviceability and to detect incipient failure by measuring the mechanical or electrical characteristics of an item and comparing those characteristics with prescribed standards.
- c. Semite.** Operations required periodically to keep an item in proper operating condition, i.e., to clean (decontaminate), to preserve, to drain, to paint, or to replenish fuel, lubricants, hydraulic fluids, or compressed air supplies.
- d. Adjust.** To maintain, within prescribed limits, by bringing into proper or exact position, or by setting the operating characteristics to the specified parameters.
- e. Align.** To adjust specified variable elements of an item to bring about optimum or desired performance.
- f. Calibrate.** To determine and cause corrections to be made or to be adjusted on instruments or test measuring and diagnostic equipments used in precision measurement. Consists of comparisons of two instruments, one of which is certified standard of known accuracy, to detect and adjust any discrepancy in the accuracy of the instrument being compared.
- g. Install.** The act of emplacing, seating, or fixing into position an item, part, module (component or assembly) in a manner to allow the proper functioning of the equipment or system.
- h. Replace.** The act of substituting a serviceable like type part, subassembly, or module (component or assembly) for an unserviceable counterpart.

i. Repair. The application of maintenance services (inspect, test, service, adjust, calibrate, replace) or other maintenance actions (welding, grinding, riveting, straightening, facing, remachining, or resurfacing) to restore serviceability to an item by correcting specific damage, fault, malfunction, or failure in a part, subassembly, module (component or assembly), end item, or system.

j. Overhaul. That maintenance effort (service/action) necessary to restore an item to a completely serviceable/operational condition as prescribed by maintenance standard (i.e., DMWR) in appropriate technical publications. Overhaul is normally the highest degree of maintenance performed by the Army. Overhaul does not normally return an item to like new condition.

k. Rebuild. Consists of those services/actions necessary for the restoration of unserviceable equipment to a like new condition in accordance with original manufacturing standards. Rebuild is the highest degree of materiel maintenance applied to Army equipment. The rebuild operation includes the act of returning to zero those age measurements (hours, miles, etc.) considered in classifying Army equipments/components.

a. Column 1, Group Number. Column 1 lists ground numbers, the purpose of which is to identify components, assemblies, subassemblies, and modules with the next higher assembly.

b. Column 2, Component/Assembly. Column 2 contains the noun names of components, assemblies, subassemblies, and modules for which maintenance is authorized.

c. Column 3, Maintenance Functions. Column 3 lists the functions to be performed on the item listed in column 2. When items are listed without maintenance functions, it is solely for purpose of having the group numbers in the MAC and RPSTL coincide.

d. Column 4, Maintenance Category. Column 4 specifies, by the listing of a "work time" figure in the appropriate subcolumn(s), the lowest level of maintenance authorized to perform the function listed in column 3. This figure represents the active time required to perform that maintenance function at the indicated category of maintenance. If the number or complexity of the tasks within the listed maintenance function vary at different maintenance categories, appropriate "work time" figures will be shown for each category. The number of task-hours specified by the "work time" figure represents the average time required to restore an item (assembly, subassembly, component, module, end item or system) to a serviceable condition under typical field operating conditions. This time includes preparation time, troubleshooting time, and quality assurance/quality control time in addition to the time required to perform the specific tasks identified for the maintenance functions authorized in the maintenance allocation chart. Subcolumns of column 4 are as follows:

C - Operator/Crew

O - Organizational

F - Direct Support

H - General Support

D - Depot

e. **Column 5, Tools and Equipment.** Column 5 specifies by code, those common tool sets (not individual tools) and special tools, test, and support equipment required to perform the designated function.

f. **Column 6, Remarks.** Column 6 contains an alphabetic code which leads to the remark in section IV, Remarks, which is pertinent to the item opposite the particular code.

B-4 TOOL AND TEST EQUIPMENT REQUIREMENTS (SECT. III).

a. **Tool or Test Equipment Reference Code.** The numbers in this column coincide with the numbers used in the tools and equipment column of the MAC. The numbers indicate the applicable tool or test equipment for the maintenance functions.

b. **Maintenance Category.** The codes in this column indicate the maintenance category allocated the tool or test equipment.

c. **Nomenclature.** This column lists the noun name and nomenclature of the tools and test equipment required to perform the maintenance functions.

d. **National/NATO Stock Number.** This column list the National/NATO stock number of the specific tool or test equipment.

e. **Tool Number.** This column lists the manufactuere's part number of the tool followed by the Federal Supply Code for manufacturers (5-digit) in parentheses.

B-5 REMARKS (SECT. IV).

a. **Reference Code.** This code refers to the appropriate item in section II, column 6.

b. **Remarks.** This column provides the required explanatory information necessary to clarify items appearing in section II.

**SECTION II MAINTENANCE ALLOCATION CHART
FOR**

Multiplexer TD-1288()/GRC

(1) GROUP NUMBER	(2) COMPONENT/ASSEMBLY	(3) MAINTENANCE FUNCTION	(4) MAINTENANCE CATEGORY					(5) TOOLS AND EQPT.	(6) REMARK
			C	O	F	H	D		
00	TRANSCEIVER MULTIPLEXER TD1288()/GRC	Inspect	0.10					12,14,15,16	B
		Install		0.20					A
		Repair	0.40	0.20					
01	COUPLER, CU-2266()/GRC	Adjust		0.40				12 3,5,6,7,9, 10,17 thru 26	C
		Test		0.50					A
		Replace					4.00		
02	BANDPASS FILTER F-1482()/GRC	Repair					8.00	12 3,5,6,7,9, 10,17 thru 26	A
		Overhaul		0.20			4.60		
		Replace					7.30		
03	MULTIPLEXER CASE, CY-7775()/GRC	Repair					1 thru 7, 10, 11,17 thru 26	A	
		Overhaul		0.10			2.00		12 13

**SECTION II MAINTENANCE ALLOCATION CHART
FOR**

MULTI PLEXER TD-1289() (V)/GRC

(1) GROUP NUMBER	(2) COMPONENT/ASSEMBLY	(3) MAINTENANCE FUNCTION	(4) MAINTENANCE CATEGORY					(5) TOOLS AND EQPT.	(6) REMARKS
			C	O	F	H	D		
00	TRANSCEIVER MULTIPLEXER TD-1289() (V)/GRC	Inspect	3.20	0.20				12,14,15,16 12	B
		Install		0.20					A
		Repair	0.40	0.50					C
		Adjust Test		1.00					12
01	COUPLER, CU-2267()/GRC	Replace					4.00	3,5,6,7,9, 10,17 thru 26	A
		Repair					8.00		
02	BANDPASS FILTER F-1482()/GRC	Overhaul					4.60	2 1 thru 7, 10,11,17 thru 26	A
		Replace		0.20			7.30		
03	TERMINATION UNIT, MX-10080()/GRC	Repair					0.10	12 8,13	A
		Test		0.20					
04	MULTIPLEXER CASE, CY-7776()/GRC	Replace		0.10			2.00	12 13	A
		Overhaul							

**SECTION III TOOL AND TEST EQUIPMENT REQUIREMENTS
FOR**

MULTI PLEXER TD-1288()/GRC AND TD-1289() (V)/GRC

TOOL OR TEST EQUIPMENT REF CODE	MAINTENANCE CATEGORY	NOMENCLATURE	NATIONAL/NATO STOCK NUMBER	TOOL NUMBER
1	D	AMPLIFIER, POWER 100-UATT RF		ENI 3100L
2	D	VOLTMETER, VECTOR ME-512U	6625-00-929-1897	HP8405A
3	D	GENERATOR, SIGNAL SG-1112(V)1/U	6625-00-566-3067	
4	D	RF LOAD, 50 OHMS	5935-00-813-9111	HP908A
5	D	RF ANALYZER, MAIN FRAME		WILTRON 640
6	D	RF DETECTOR		WILTRON 7B50
7	D	GENERATOR, SWEEP		WILTRON 640G50
8	D	METER, VECTOR IMPEDANCE	6625-00-061-0225	HP4815A
9	D	FILTER, BANDPASS F - 1482()/GRC		RIC 558-6101-001
10	D	TERMINATION UNIT MX-10080()/GRC		RIC 518-6104-001
11	D	COUPLER CU-2266()/GRC, CU-2267()/GRC		RIC 558-6105-001
12	0	TOOL KIT, ELECTRONIC EQUIPMENT TD-101/G	5180-00-064-5178	
13	D	TOOL KIT, ELECTRONIC EQUIPMENT TD-100/G	5180-00-605-0079	
14	0	DRILL, ELECTRIC, PORTABLE 1/4 INCH	5130-00-889-8994	
15	0	DRILL SET, TWIST, HIGH-SPEED STEEL DRILL SIZE 1/16 - 1/4	5133-00-618-7783	
16	0	CASE, TWIST DRILL	5140-00-837-5313	
17	D	LOG AMPLIFIER		WILTRON 640E
18	D	SWR AUTOTESTER		WILTRON 6B50
19	D	DIGITAL MULTIMETER	6625-01-115-2141	FLUKE 8050A
20	D	RF DIRECTIONAL WATTMETER	6625-00-649-5070	BIRD 43
21	D	ELEMENT, RF DIRECTIONAL WATTMETER	6625-00-269-4459	BIRD 100A
22	D	ELEMENT, RD DIRECTIONAL WATTMETER	6625-00-854-4043	BIRD 100B
23	D	20/80 - WATT RF ABSORPTION WATTMETER	6625-00-308-2668	BIRD 612
24	D	RF VOLTMETER	6625-01-030-5260	BOONTON 92BD
25	D	COAXIAL ADAPTER		RIC 558-6251-001
26	D	500 WATT RF ABSORPTION WATTMETER	6625-01-111-6622	BIRD 6734

SECTION IV. REMARKS

REFERENCE CODE	REMARKS
A	REPAIR IS DONE BY REPLACEMENT.
B	VISUAL EXAMINATION OF TRANSCEIVER.
C	VISUAL READING ON METER.

APPENDIX C

COMPONENTS OF END ITEM LIST AND BASIC ISSUE ITEMS LISTS

SECTION I

INTRODUCTION

C-1 SCOPE.

These items, when assembled, comprise the 2- through 5-channel multiplexer and must accompany them whenever they are transferred or turned in. The illustration will help you identify these items.

C-2 GENERAL.

This Components of End Item List is divided into the following sections:

a. Section II. Integral Components of the End Item.

These items, when assembled, comprise the 2- through 5-channel multiplexer and must accompany them whenever they are transferred or turned in. The illustration will help you identify these items.

b. Section III. Basic Issue Items. Not applicable.

C-3 EXPLANATION OF COLUMNS.

a. Illustration. This column is divided as follows:

- (1) **Figure number.** Indicates the figure number of the illustration on which the item is shown.
- (2) **Item number.** The number used to identify item called out in the illustration.

b. National Stock Number. Indicates the National Stock number assigned to the item and which will be used for requisitioning.

c. Description. Indicates the Federal item name and, if required, a minimum description to identify the item. The part number indicates the primary number used by the manufacturer, which controls the design and characteristics of the item by means of its engineering drawings, specifications, standards, and inspection requirements to identify an item or range of items. Following the part number, the Federal Supply Code for Manufacturers (FSCM) is shown in parentheses.

d. Location. If the physical location is necessary to help you inventory each major item, it will be listed in this column.

e. Usable on Code. Not applicable.

f. Quantity Required (Qty Reqd). This column lists the quantity of each item required for a complete major item.

g. Quantity. This column is left blank for use during an inventory. Under the Rcvd column, list the quantity you actually receive on your major item. The Date columns are for your use when you inventory the major item.

SECTION II

INTEGRAL COMPONENTS OF END ITEM

(1) ILLUSTRATION		(2) NATIONAL STOCK NUMBER	(3) DESCRIPTION PART NUMBER (FSCM)	(4) LOCATION	(5) USABLE ON CODE	(6) QTY REQD	(7) QUANTITY	
(A) FIG NO	(B) ITEM NO						RCVD	DATE
C-1	1	5820-01-090-1414	2-Channel Multiplexer TD-1288 ()/GRC					
C-2	5	5915-01-090-9450	Band-pass Filter F-1482 ()/GRC			2		
C-2	7	5820-01-091-0836	Coupler CU-2266 ()/GRC			1		
C-3	9	5820-01-091-0835	Multiplexer Case CY-7775 ()/GRC			1		
C-1	2	5820-01-090-9452	3-Channel Multiplexer TD-1289 () (V)3/GRC					
C-2	5	5915-01-090-9450	Band-pass Filter F-1482 ()/GRC			3		
C-2	8	5820-01-091-0837	Coupler CU-2267 ()/GRC			1		
C-2	6	5820-01-091-0834	Termination Unit MX-10080 ()/GRC			2		
C-3	10	5820-01-090-6802	Multiplexer Case CY-7776 ()/GRC			1		

SECTION III

INTEGRAL COMPONENTS OF END ITEM

(1) ILLUSTRATION		(2) NATIONAL STOCK NUMBER	(3) DESCRIPTION PART NUMBER (FSCM)	(4) LOCATION	(5) USABLE ON CODE	(6) QTY REQD	(7) QUANTITY	
(A) FIG NO	(B) ITEM NO						RCVD	DATE
C-1	3	5820-01-090-9451	4-Channel Multiplexer TD-1289 () (V)2/GRC					
C-2	5	5915-01-090-9450	Band-pass Filter F-1482 ()/GRC			4		
C-2	8	5820-01-091-0837	Coupler CU-2267 ()/GRC			1		
C-2	6	5820-01-091-0834	Termination Unit MX-10080 ()/GRC			1		
C-3	10	5820-01-091-6802	Multiplexer Case CY-7776 ()/GRC			1		
C-1	4	5820-01-090-5407	5-channel Multiplexer TD-1289 () (V)1/GRC					
C-2	5	5915-01-090-9450	Band-pass Filter F-1482 ()/GRC			5		
C-2	8	5820-01-091-0837	Coupler CU-2267 ()/GRC			1		
C-3	10	5820-01-090-6802	Multiplexer Case CY-7776 ()/GRC			1		

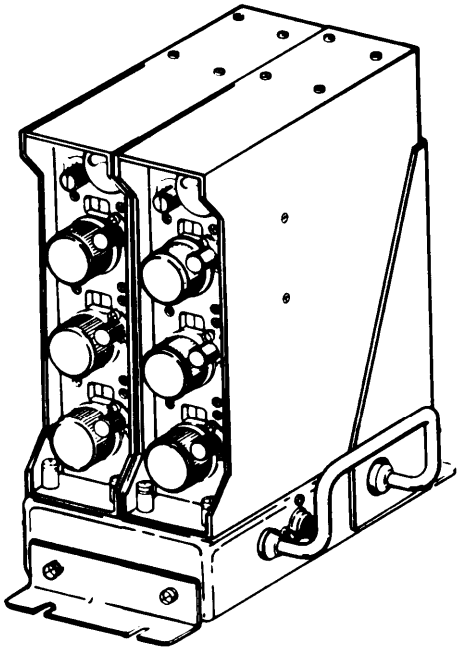

1 2-CHANNEL MULTIPLEXER
TO - 1288()GRC

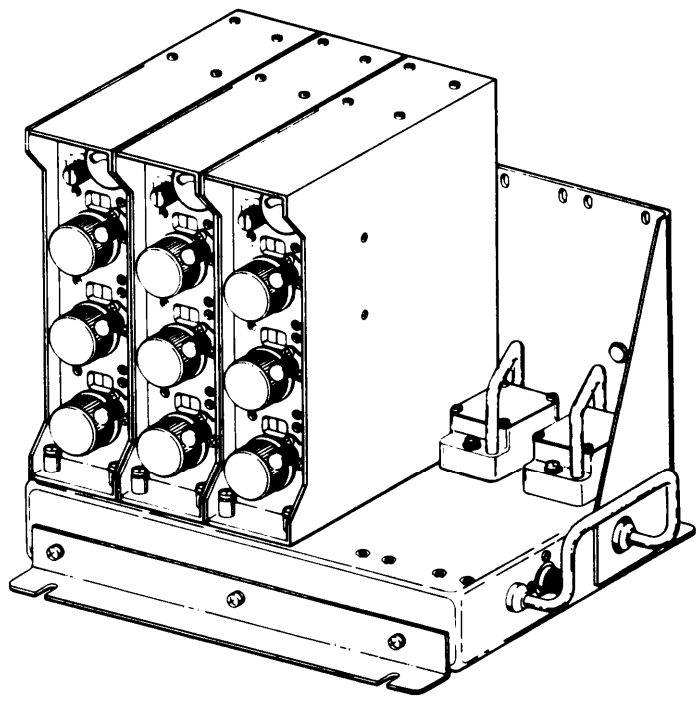

2 3-CHANNEL MULTIPLEXER
TD - 1289() (V) 3/GRC

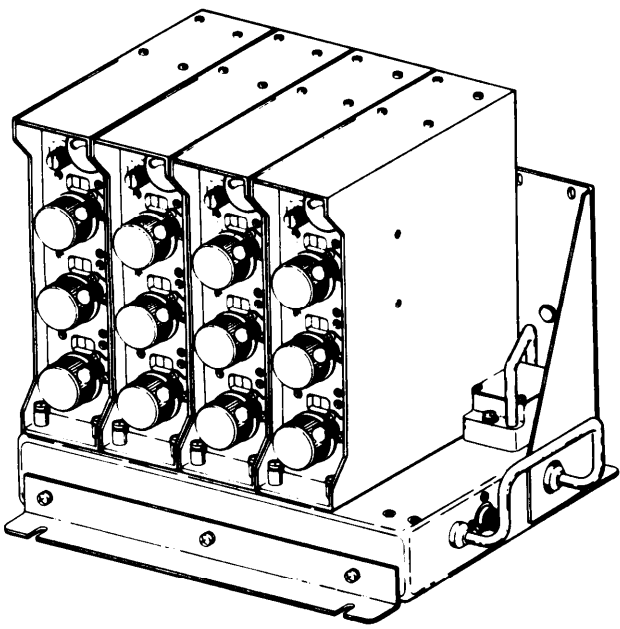

3 4-CHANNEL MULTIPLEXER
TD-12890(V)2/GRC

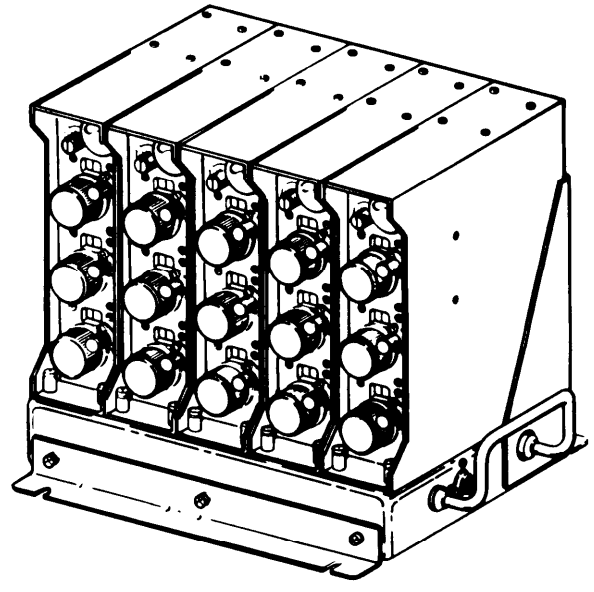

4 5-CHANNEL MULTIPLEXER
TD-12890(V)1/GRC

Figure C-1

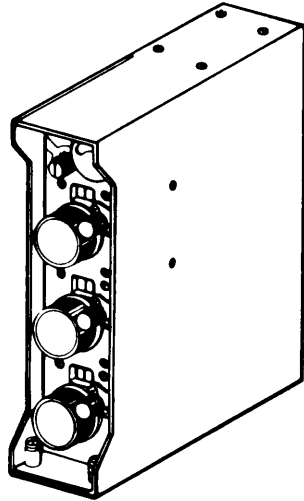

5 BAND-PASS FILTER
F-1482()/GRC

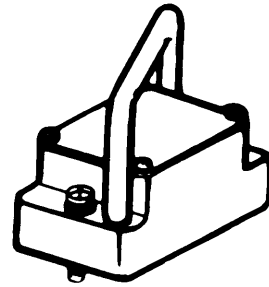

6 TERMINATION UNIT
MX-10080()/GRC

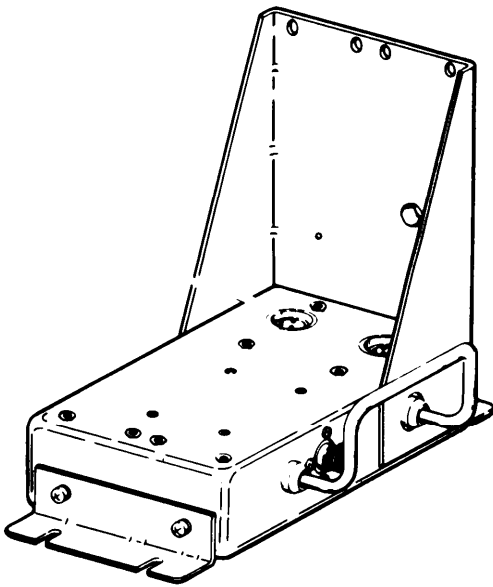

7 COUPLER
CU-2288 ()/GRC

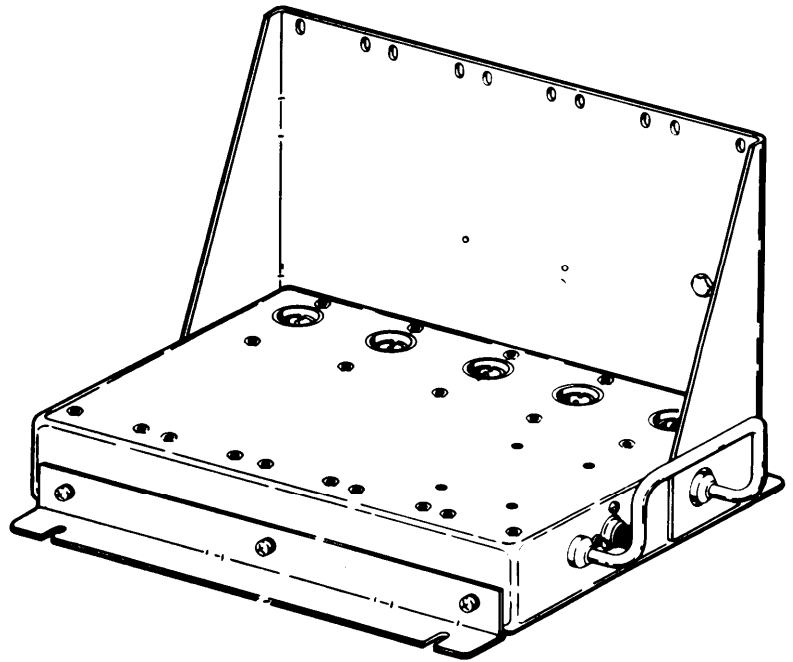

8 COUPLER,
CU-2267()/GRC

Figure C-2

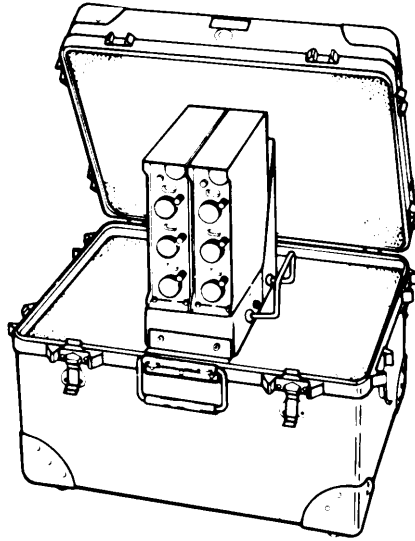

9 2-CHANNEL MULTIPLEXER AND MULTIPLEXER CASE

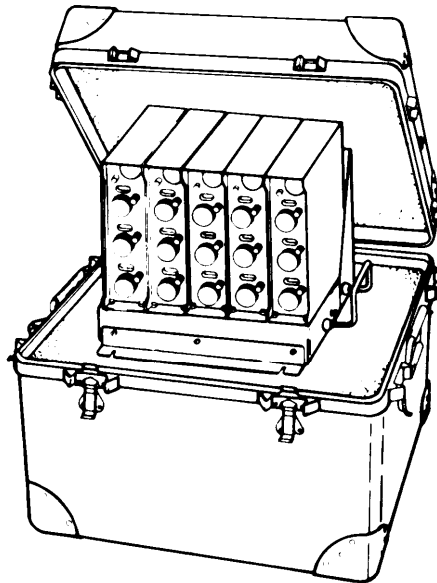

10 5-CHANNEL MULTIPLEXER AND MULTIPLEXER CASE

Figure C-3

APPENDIX E

EXPENDABLE SUPPLIES AND MATERIALS

SECTION I

INTRODUCTION

E-1 SCOPE.

This appendix lists expendable supplies and materials you will need to operate and maintain the multiplexer. These items are authorized to you by CTA 50-970, Expendable Items (Except Medical, Class V, Repair Parts, and Heraldic Items).

E-2 EXPLANATION OF COLUMNS.

a. Column 1 - Item Number. This number is assigned to the entry in the listing and is referenced in the narrative instructions to identify the material (e.g., "Use cleaning compound, item 5, App. D").

b. Column 2- Level. This column identifies the lowest level of maintenance that requires the listed item.

C - Operator/Crew

O - Organizational Maintenance

F - Direct Support Maintenance

H - General Support Maintenance

c. Column 3 - National Stock Number. This is the National stock number assigned to the item; use it to request or requisition the item.

d. Column 4 - Description. Indicates the Federal item name and if required, a description to identify the item. The last line for each item indicates the part number followed by the Federal Supply Code for Manufacturer (FSCM) in parentheses, if applicable.

e. Column 5 - Unit of Measure (U/M). Indicates the measure used in performing the actual maintenance function. This measure is expressed by a two-character alphabetical abbreviation (e.g., ea, in, pr). If the unit of measure differs from the unit of issue, requisition the lowest unit of issue that will satisfy your requirements.

SECTION II EXPENDABLE SUPPLIES AND MATERIALS LIST

(1) ITEM NO.	(2) LEVEL	(3) NATIONAL STOCK NUMBER	(4) DESCRIPTION PART NO. AND FSCM	(5) U/M
	0	6850-00-105-3084	Trichlorotrifluoroethane	QT

By Order of the Secretary of the Army:

Official:

JOHN A. WICKHAM JR.
General, United States Army
Chief of Staff

ROBERT M. JOYCE
Major General, United States Army
The Adjutant General

Distribution:

To be distributed in accordance with special list.

★ U.S. GOVERNMENT PRINTING OFFICE ; 1990 O¹- 261-872 (20632)



THEN... JOT DOWN THE DOPE ABOUT IT ON THIS FORM. CAREFULLY TEAR IT OUT. FOLD IT AND DROP IT IN THE MAIL!

SOMETHING WRONG WITH THIS PUBLICATION?

FROM (PRINT YOUR UNIT'S COMPLETE ADDRESS)

Commander
Stateside Army Depot
ATTN: AMSTA-US
Stateside, N.J. 07703

DATE SENT

10 July 1975

PUBLICATION NUMBER

TM 11-5840-340-12

PUBLICATION DATE

23 Jan 74

PUBLICATION TITLE

Radar Set AN/PRC-76

BE EXACT PIN-POINT WHERE IT IS

PAGE NO	PARA-GRAPH	FIGURE NO	TABLE NO
---------	------------	-----------	----------

2-25	2-28		
------	------	--	--

3-10	3-3		3-1
------	-----	--	-----

5-6	5-8		
-----	-----	--	--

F03

IN THIS SPACE TELL WHAT IS WRONG AND WHAT SHOULD BE DONE ABOUT IT:

Recommend that the installation antenna alignment procedure be changed throughout to specify a 2° IFF antenna lag rather than 1°.

REASON: Experience has shown that with only a 1° lag, the antenna servo system is too sensitive to wind gusting in excess of 25 knots, and has a tendency to rapidly accelerate and decelerate as it hunts, causing strain to the drivetrain. Hunting is minimized by adjusting the lag to 2° without degradation of operation.

Item 5, Function column. Change "2 db" to "3db."

REASON: The adjustment procedure for the TRANS POWER FAULT indicator calls for a 3 db (500 watts) adjustment to light the TRANS POWER FAULT indicator.

Add new step f.1 to read, "Replace cover plate removed in step e.1, above."

REASON: To replace the cover plate.

Zone C 3. On J1-2, change "+24 VDC to "+5 VDC."

REASON: This is the output line of the 5 VDC power supply. +24 VDC is the input voltage.

PRINTED NAME, GRADE OR TITLE, AND TELEPHONE NUMBER

SSG I. M. DeSpiritof 999-1776

SIGN HERE

DA FORM 2028-2
1 JUL 79

PREVIOUS EDITIONS ARE OBSOLETE.

P.S.--IF YOUR OUTFIT WANTS TO KNOW ABOUT YOUR RECOMMENDATION MAKE A CARBON COPY OF THIS AND GIVE IT TO YOUR HEADQUARTERS

TEAR ALONG PERFORATED LINE

RECOMMENDED CHANGES TO EQUIPMENT TECHNICAL PUBLICATIONS



SOMETHING WRONG WITH THIS PUBLICATION?

THEN...JOT DOWN THE DOPE ABOUT IT ON THIS FORM. CAREFULLY TEAR IT OUT, FOLD IT AND DROP IT IN THE MAIL.

FROM: (PRINT YOUR UNIT'S COMPLETE ADDRESS)

DATE SENT

PUBLICATION NUMBER
TM 11-5820-880-12

PUBLICATION DATE

PUBLICATION TITLE

BE EXACT PIN-POINT WHERE IT IS

PAGE NO.	PARA-GRAPH	FIGURE NO.	TABLE NO.

IN THIS SPACE TELL WHAT IS WRONG AND WHAT SHOULD BE DONE ABOUT IT:

TEAR ALONG PERFORATED LINE

PRINTED NAME GRADE OR TITLE AND TELEPHONE NUMBER

SIGN HERE

DA FORM 2028-2
1 JUL 79

PREVIOUS EDITIONS ARE OBSOLETE

P.S.--IF YOUR OUTFIT WANTS TO KNOW ABOUT YOUR RECOMMENDATION MAKE A CARBON COPE OF THIS AND GIVE IT TO YOUR HEADQUARTERS.

FILL IN YOUR
UNIT'S ADDRESS

FOLD BACK

DEPARTMENT OF THE ARMY

OFFICIAL BUSINESS
PENALTY FOR PRIVATE USE \$300

POSTAGE AND FEES PAID
DEPARTMENT OF THE ARMY
DOD 314



TEAR ALONG PERFORATED LINE

Commander
US Army Communications-Electronics Command
and Fort Monmouth
ATTN: DRSEL-ME-MP
Fort Monmouth, New Jersey 07703

THE METRIC SYSTEM AND EQUIVALENTS

WEIGHT MEASURE

1 Centimeter = 10 Millimeters = 0.01 Meters = 0.3937 Inches
 1 Meter = 100 Centimeters = 1000 Millimeters = 39.37 Inches
 1 Kilometer = 1000 Meters = 0.621 Miles

WEIGHTS

1 Gram = 0.001 Kilograms = 1000 Milligrams = 0.035 Ounces
 1 Kilogram = 1000 Grams = 2.2 lb.
 1 Metric Ton = 1000 Kilograms = 1 Megagram = 1.1 Short Tons

LIQUID MEASURE

1 Milliliter = 0.001 Liters = 0.0338 Fluid Ounces
 1 Liter = 1000 Milliliters = 33.82 Fluid Ounces

SQUARE MEASURE

1 Sq. Centimeter = 100 Sq. Millimeters = 0.155 Sq. Inches
 1 Sq. Meter = 10,000 Sq. Centimeters = 10.76 Sq. Feet
 1 Sq. Kilometer = 1,000,000 Sq. Meters = 0.386 Sq. Miles

CUBIC MEASURE

1 Cu. Centimeter = 1000 Cu. Millimeters = 0.06 Cu. Inches
 1 Cu. Meter = 1,000,000 Cu. Centimeters = 35.31 Cu. Feet

TEMPERATURE

$5/9(^{\circ}\text{F} - 32) = ^{\circ}\text{C}$
 212° Fahrenheit is equivalent to 100° Celsius
 90° Fahrenheit is equivalent to 32.2° Celsius
 32° Fahrenheit is equivalent to 0° Celsius
 $9/5^{\circ}\text{C} + 32 = ^{\circ}\text{F}$

APPROXIMATE CONVERSION FACTORS

TO CHANGE	TO	MULTIPLY BY
Inches	Centimeters	2.540
Feet	Meters	0.305
Yards	Meters	0.914
Miles	Kilometers	1.609
Square Inches	Square Centimeters	6.451
Square Feet	Square Meters	0.093
Square Yards	Square Meters	0.836
Square Miles	Square Kilometers	2.590
Acres	Square Hectometers	0.405
Cubic Feet	Cubic Meters	0.028
Cubic Yards	Cubic Meters	0.765
Fluid Ounces	Milliliters	29.573
its	Liters	0.473
arts	Liters	0.946
allons	Liters	3.785
Ounces	Grams	28.349
Pounds	Kilograms	0.454
Short Tons	Metric Tons	0.907
Pound-Feet	Newton-Meters	1.356
Pounds per Square Inch	Kilopascals	6.895
Miles per Gallon	Kilometers per Liter	0.425
Miles per Hour	Kilometers per Hour	1.609

TO CHANGE	TO	MULTIPLY BY
Centimeters	Inches	0.394
Meters	Feet	3.280
Meters	Yards	1.094
Kilometers	Miles	0.621
Square Centimeters	Square Inches	0.155
Square Meters	Square Feet	10.764
Square Meters	Square Yards	1.196
Square Kilometers	Square Miles	0.386
Square Hectometers	Acres	2.471
Cubic Meters	Cubic Feet	35.315
Cubic Meters	Cubic Yards	1.308
Milliliters	Fluid Ounces	0.034
Liters	Pints	2.113
Liters	Quarts	1.057
ers	Gallons	0.264
ms	Ounces	0.035
ograms	Pounds	2.205
Metric Tons	Short Tons	1.102
Newton-Meters	Pounds-Feet	0.738
Kilopascals	Pounds per Square Inch	0.145
ometers per Liter	Miles per Gallon	2.354
ometers per Hour	Miles per Hour	0.621



PIN: 053922-000